

(bedcolab)

Adaptable laboratory furniture systems



Because the only constant is...



Symphony

- The ultimate in flexibility
- Fully mobile table system
- «Add-a-leg» or «add-a-bench» features can transform from single to island configuration and vice versa
- Totally integrated quick disconnect plumbing and electrical services
- Available in island and wall mount configurations
- Available with multiple upper shelving arrangements
- Easily configured to sitting or standing heights
- Convenient access to services

Allegro

- Highly adaptable cantilever system with full height adjustment of the work surfaces and upper shelving
- No support legs for unobstructed floor under the counter
- Designed to accommodate our **Opus** suspended cabinets, the **Allegro** system can also be used with floor mounted or mobile cabinets
- Available in island and wall mount configurations
- Available with multiple upper shelving arrangements
- Easy access to center service chase



Concert

- Sleek and elegant design
- Sturdy and vibration resistant
- Available in sitting and standing height
- The support legs are recessed to allow for more flexible seating arrangements
- Available in island and wall mount configurations
- Designed to accommodate our **Opus** suspended cabinets, the **Concert** system can also be used with floor mounted or mobile cabinets
- Available with multiple upper shelving arrangements
- Easy access to center service chase

Chorus

- Rigid design provides superior vibration resistance
- High load bearing design
- Cost effective
- Available in sitting or standing heights
- Available in wall mount and island designs
- Designed to accommodate our **Opus** suspended cabinets, the **Chorus** system can also be used with floor mounted or mobile cabinets.
- Available with multiple upper shelving arrangements
- Easy access to center service chase



Bedcolab adaptable furniture systems

In these days of rapidly evolving science, laboratories face the growing challenge of adapting their space to the changing needs of their research. Bedcolab offers an extensive range of adaptable furniture systems from flexible bench type systems to fully mobile table units with integrated umbilical service connections.

Regardless of which architectural style you choose, the **Symphony**, **Allegro**, **Concert** and **Chorus** series can quickly and easily be reconfigured or relocated using simple hand tools. You can modify a work station or create a new one. You can add cabinets or a new shelving system in a matter of minutes. Adaptability that really works in a laboratory environment.

All Four systems can be configured as island assemblies or wall core assemblies and can be fitted with either floor mounted casework, mobile cabinets or our **OPUS** suspended cabinets that are designed to slide laterally under the bench sections allowing the lab technician to personalize his or her space instantly.

The **Allegro**, **Concert** and **Chorus** systems offer rear mounted service chases with removable panels for convenient access to plumbing, electrical and other services. To create a designated lab space, our wall panel system can be used to provide ceiling to counter separation. Whatever technology throws your way, we have a solution to meet your needs.

Be ready for tomorrow with the right system today



All systems meet or exceed SEFA (Scientific Equipment & Furniture Association) requirements

Manufactured under our ISO 9001:2000 Quality Program



High value sustainable designs to meet environmental challenges of the laboratory industry

Chorus System

Our value leader. This sturdy, cost effective system has always been a favorite. It offers the same stable work environment as floor mounted cabinets but with the added benefit of flexibility in cabinet configuration. It features a rigid 'P' shaped bench support system for high load bearing and vibration resistance. Plumbing and other services are fully accessible by removing the convenient front access panels. The horizontal members of the frame assembly are designed to work with our **Opus** suspended cabinets that can easily be slide from side to side allowing the user to quickly adapt the space to his or her needs. Because each lab has it's own requirements, the **Chorus** system can also be used in combination with standard floor mounted casework, mobile cabinets and a multitude of adjustable upper shelving arrangements.

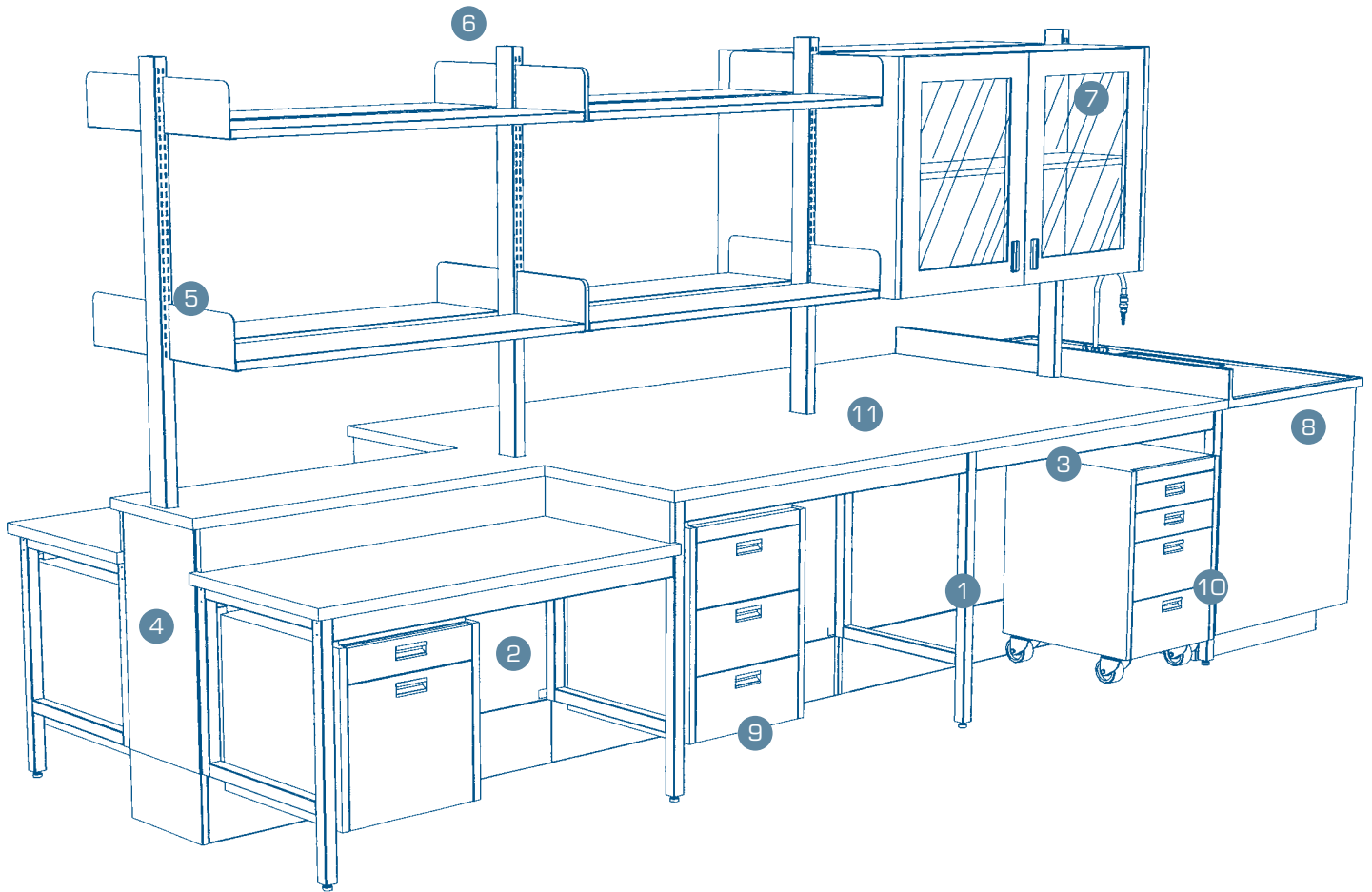

Island Type

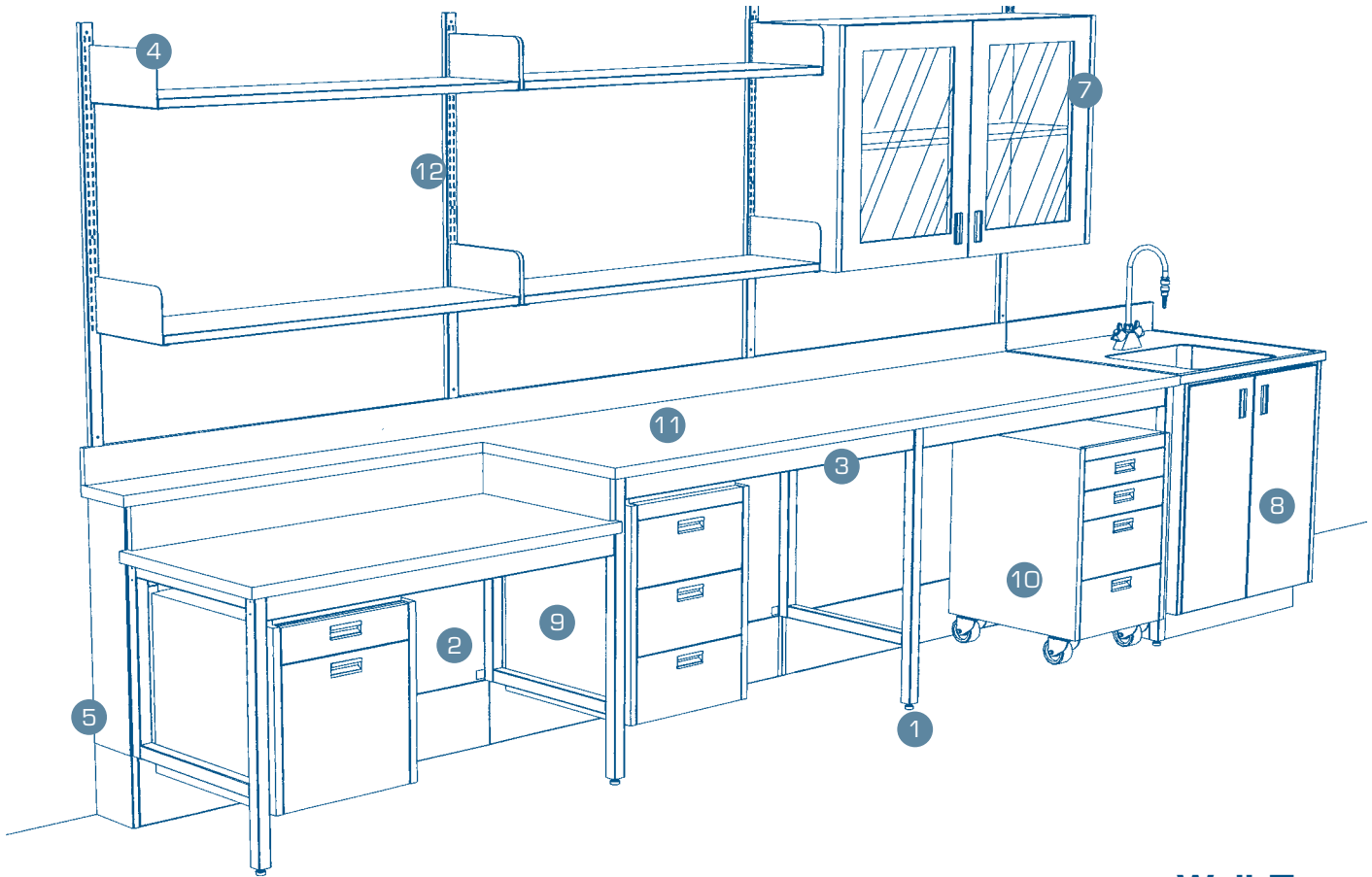

Wall Type

Features

- 1 P Leg counter support
- 2 Service chase cover panel
- 3 Horizontal support member
- 4 Shelf support set
- 5 End closing panel
- 6 Double post assembly
- 7 Wall storage cabinet
- 8 Additional **Forté** cabinet
- 9 **Opus** suspended cabinet
- 10 Mobile cabinet
- 11 Work surface
- 12 Single Post assembly

Characteristics

- Vibration resistant. Available in sitting or standing height
- Full access to rear services
- Can accommodate **Opus** suspended cabinets
- Adjustable to 1 inch increments
- For lateral access to services
- Supports counter tops and shelving for Island benches
- For protected storage
- Adds storage and is available as a sink unit
- Slides laterally under the counter top
- Easily re-locatable to another workstation
- Available in many materials and finishes
- Supports upper storage cabinets and shelving at wall benches

*Additional technical information is available on our CD Rom

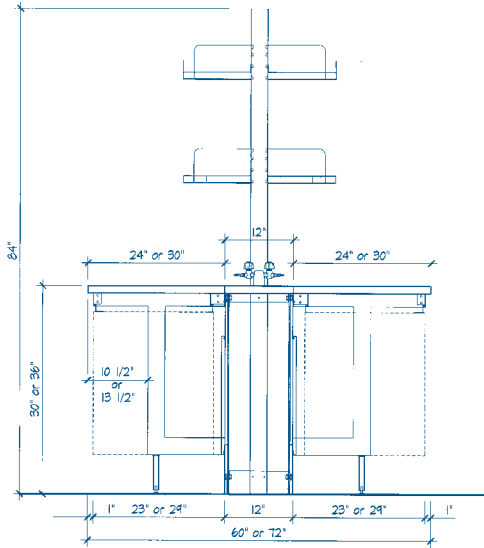

Island Type

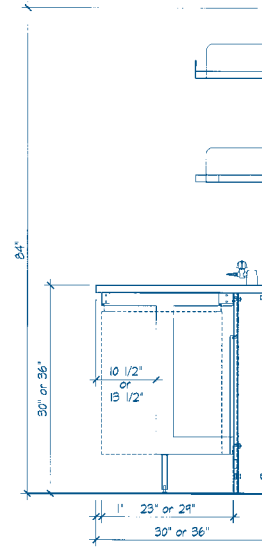

Wall Type

Concert System

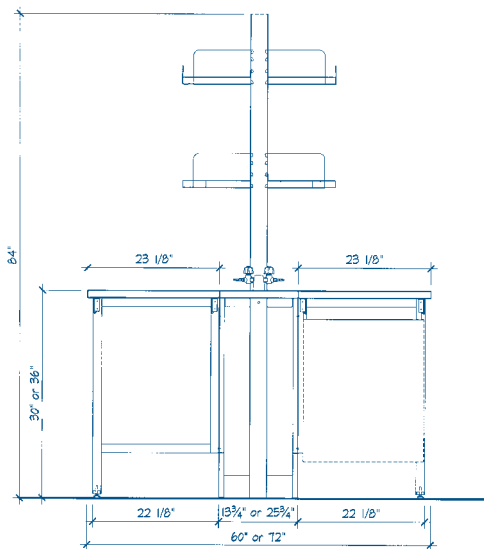

Island Type

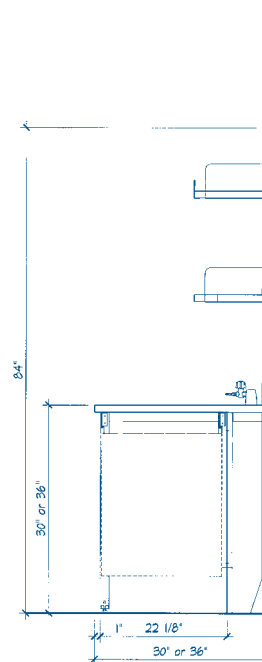

Wall Type

Chorus System

Opus Suspended Storage cabinets

We offer an assortment of under-counter cabinets designed to work with all Bedcolab adaptable systems. These cabinets include front and rear support rails that are mated to the counter structure rails. The cabinets are securely suspended under counter top. The cabinets can easily be slide laterally to any desired position.

Suspended cabinets for standing height benches: 21" deep x 24³/₄" high



1 door unit

Model no.	Width	
	inches	mm
SB1-15	15	381
SB1-18	18	457
SB1-21	21	533
SB1-24	24	610



2 door unit

SB2-30	30	762
SB2-36	36	914
SB2-42	42	1067
SB2-48	48	1219



1 drawer - 1 door unit

SB4-15-1	15	381
SB4-18-1	18	457
SB4-21-1	21	533
SB4-24-1	24	610



2 drawer - 2 door unit

SB5-30-2	30	762
SB5-36-2	36	914
SB5-42-2	42	1067
SB5-48-2	48	1219



3 drawer unit

SB7-15-3	15	381
SB7-18-3	18	457
SB7-21-3	21	533
SB7-24-3	24	610



4 drawer unit

SB7-15-4	15	381
SB7-18-4	18	457
SB7-21-4	21	533
SB7-24-4	24	610



1 file drawer - 1 drawer unit

SB11-15-2	15	381
SB11-18-2	18	457
SB11-21-2	21	533
SB11-24-2	24	610



2 door sink unit

SB16-30	30	762
SB16-36	36	914
SB16-42	42	1067
SB16-48	48	1219

Suspended cabinets for Sitting height benches: 21" deep x 18³/₄" high



1 door unit

SC1-15	15	381
SC1-18	18	457
SC1-21	21	533
SC1-24	24	610



1 file drawer - 1 drawer unit

SC11-15-2	15	381
SC11-18-2	18	457
SC11-21-2	21	533
SC11-24-2	24	610



3 drawer unit

SC7-15-3	15	381
SC7-18-3	18	457
SC7-21-3	21	533
SC7-24-3	24	610



2 door unit

SC2-30	30	762
SC2-36	36	914
SC2-42	42	1067
SC2-48	48	1219

(bedcolab)

Bedcolab Ltd
2305, Francis-Hugues Avenue
Laval, Quebec, Canada H7S 1N5
Phone: 514.384.2820 / 1.800.461.6414
Fax: 514.384.9210
E-mail: info@bedcolab.com
Web Site: www.bedcolab.com



Authorized dealer: