

Features

1	Add-on Distribution Center	Houses all services and shelving and is removable from bottom table structure
2	Service access panel	Full height access to services wiring and piping
3	Table structure	All welded structure with easy height adjustment in 2" increments
4	Work surface	Design to function with single or double-sided tables and available in various materials
5	Adjustable shelving	Adjustable in 1" increments
6	Ceiling Service Panel	Houses quick-disconnect fixtures for easy hook-up to all plumbing, data & electrical services using flexible cords and hoses
7	Electrical raceway	Raceway for electrical and communication cabling pre-wired for connection to ceiling panel
8	Storage cabinet	Designed to accommodate our Opus suspended cabinets, the Symphony system can also be used with floor mounted or mobile cabinets
9	Tack board or partition	Designed to be used by both single and double sided tables

In these days of rapidly evolving science, laboratories face the growing challenge of adapting their space to the changing needs of their research.

Bedcolab strongly believes that Symphony II offers the ultimate in flexibility over any other adaptable casework system:

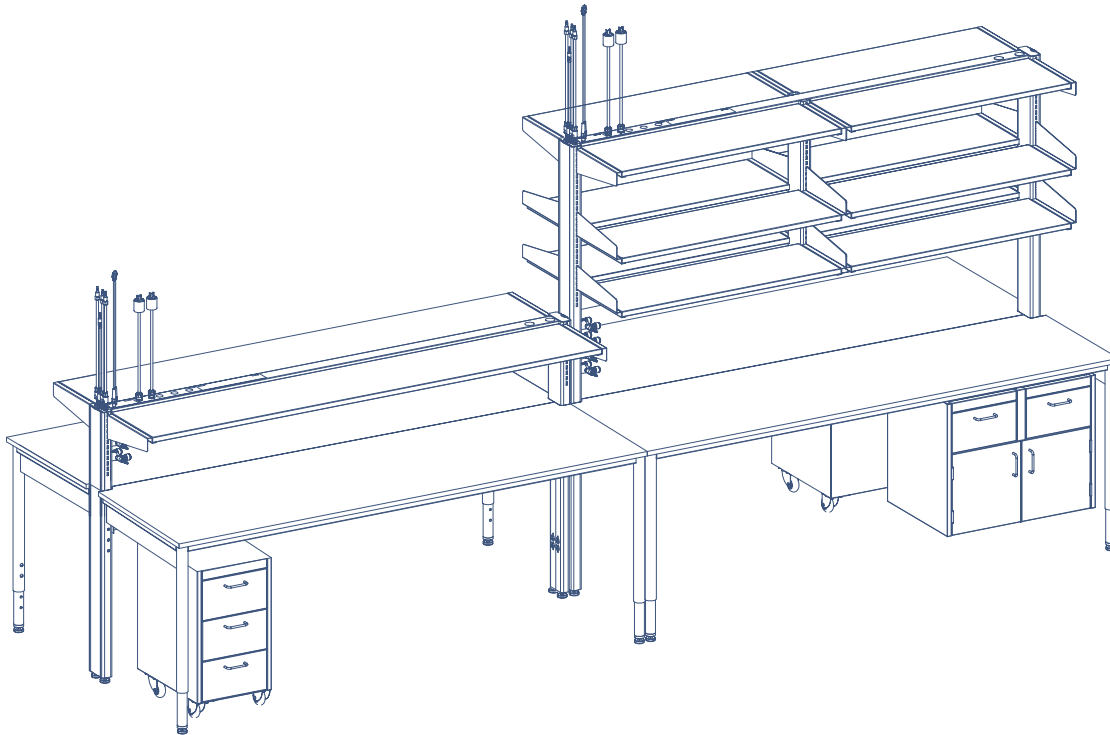

- ▶ Height adjustment of work surfaces and shelving
- ▶ Multiple components configurations.
- ▶ Mobile free standing system that permits new lab configuration at all time.
- ▶ Substantial possibilities of service integration up to four plumbing services per table and basically no limit for electrical and data outlets.
- ▶ Considerably reduced subcontractor wiring and piping needs into the labs.
- ▶ Adaptable to many types of storage cabinets including our suspended cabinets that slide laterally on the table rails.
- ▶ Various work surface options.
- ▶ Cost effective Ceiling Service Panels integrated into the system.
- ▶ Available from our twenty standard colors.

Symphony II system meets or exceeds SEFA 10-2013 - Cat 4 (Scientific Equipment & Furniture Association) requirements



Our Symphony system is designed to offer maximum lab work efficiency to the end users.

The different components are easily interchangeable to create the best laboratory ergonomic environment to all specific requirements.

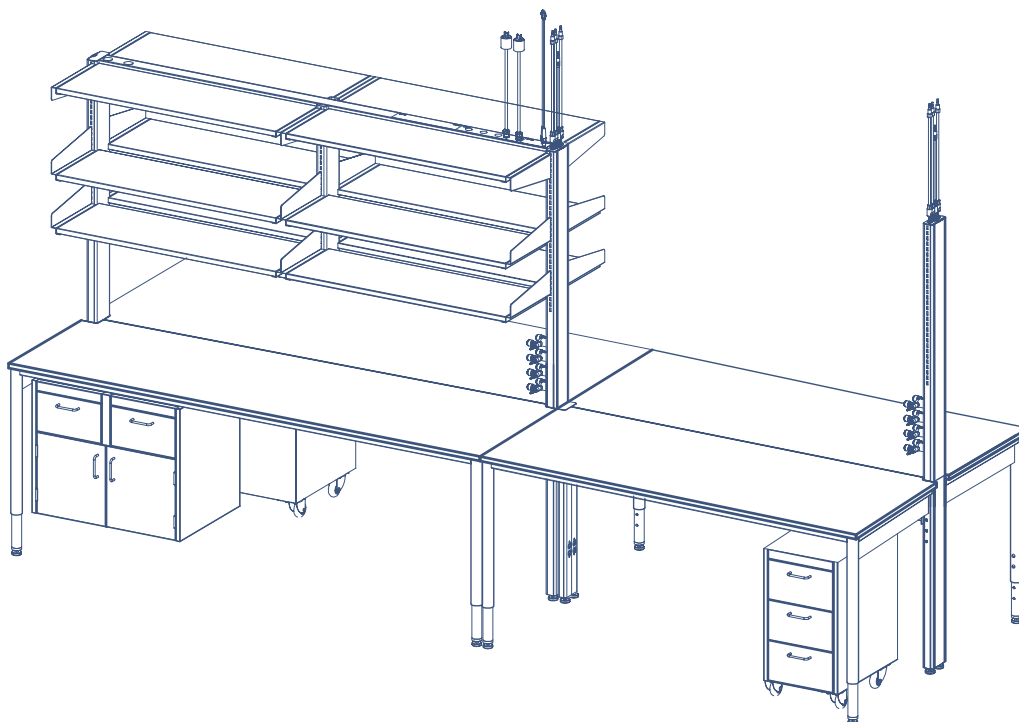

- ▶ Ergonomic and low profile table configuration.
- ▶ Multiple component configurations allow the fit for most of equipment types and sizes.
- ▶ Plumbing, electrical and data services follow the table movements into the labs.
- ▶ System allows for additional future plumbing services.
- ▶ Extremely solid table frame that permits heavy equipment loading.
- ▶ UL 962 certified table system.
- ▶ Suspended or mobile cabinets can be easily repositioned at all time.
- ▶ A lab can be redesigned without the need for construction works.
- ▶ Easily accessible Ceiling Service Panels for disconnections during table movement.

High value sustainable design to meet environmental challenges of the laboratory industry



Green by Design

Manufactured under our ISO 9001 Quality Program



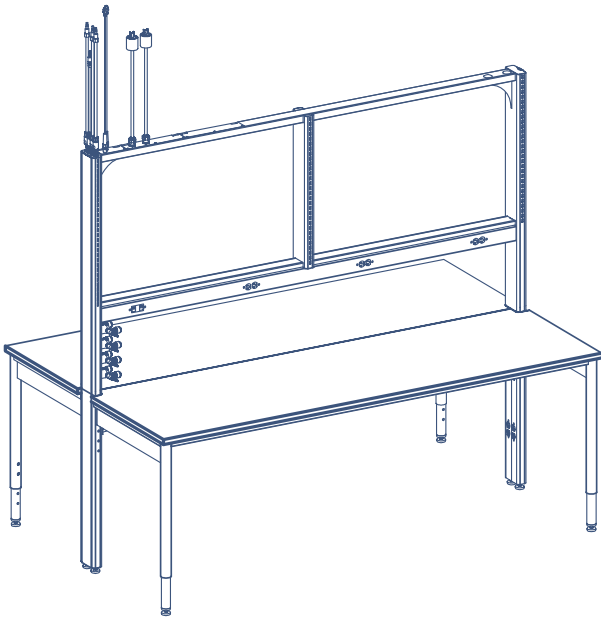

1 Double-sided table with add-on full height Distribution Center

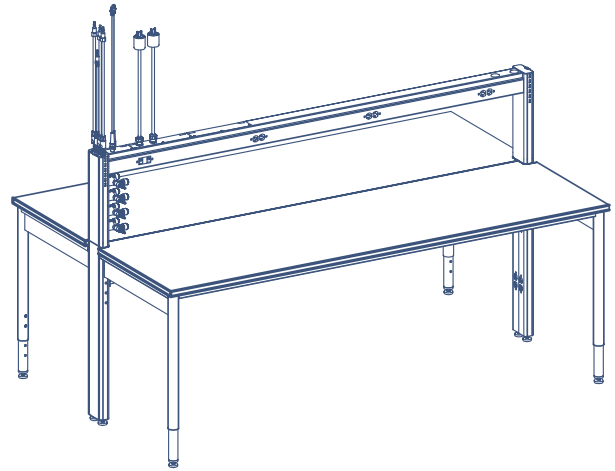

2 Double-sided table with add-on low height Distribution Center

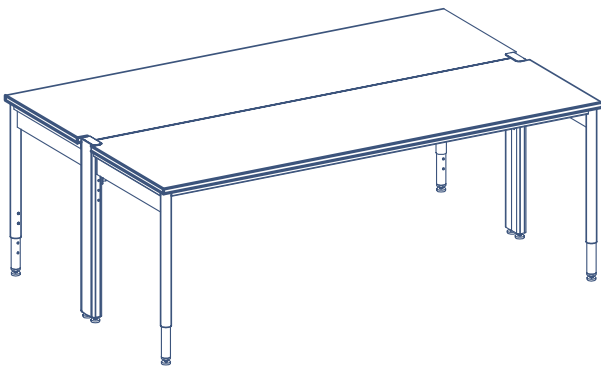

3 Double-sided table with no Distribution Center

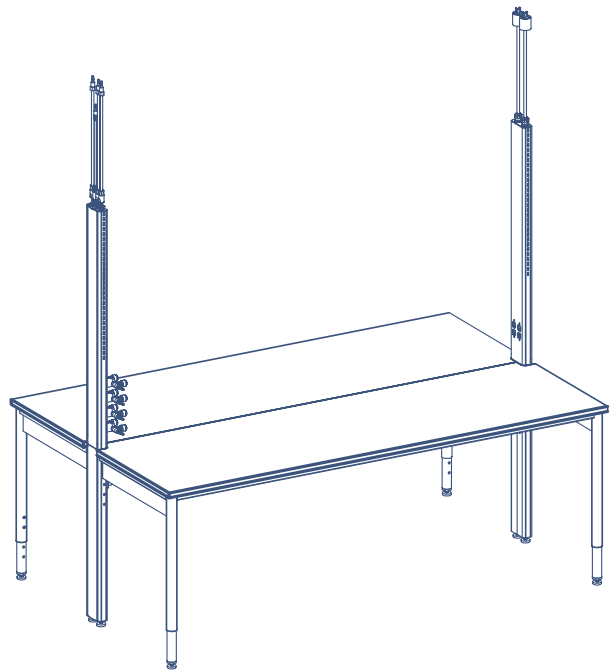

4 Double-sided table with one or two add-on end service uprights (as shown)

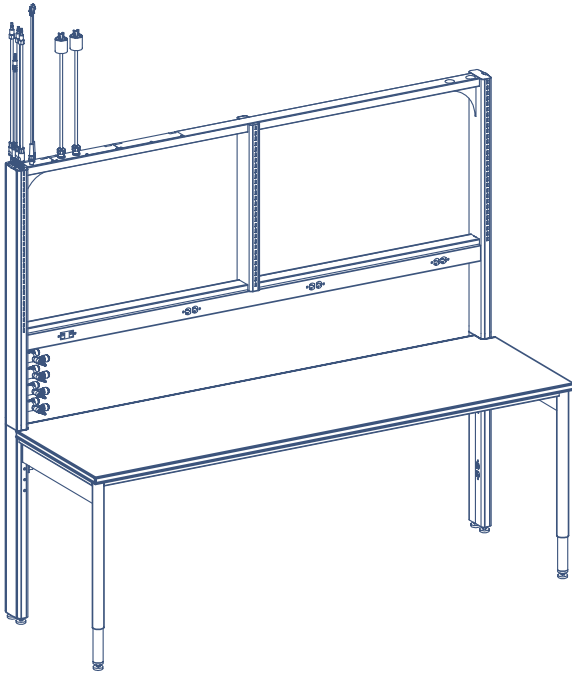

5 Single-sided table with add-on full height Distribution Center

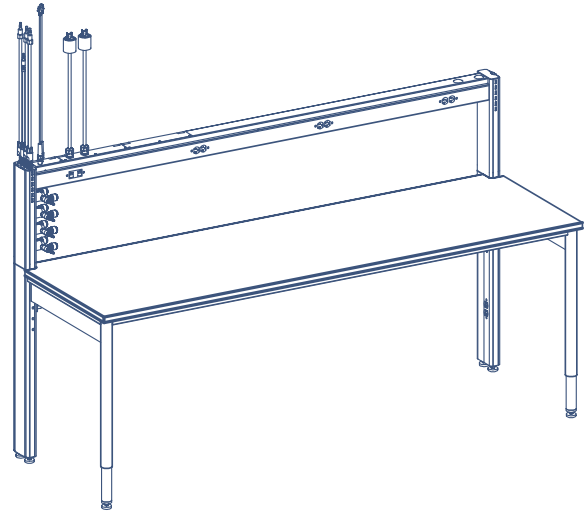

6 Single-sided table with add-on low height Distribution Center

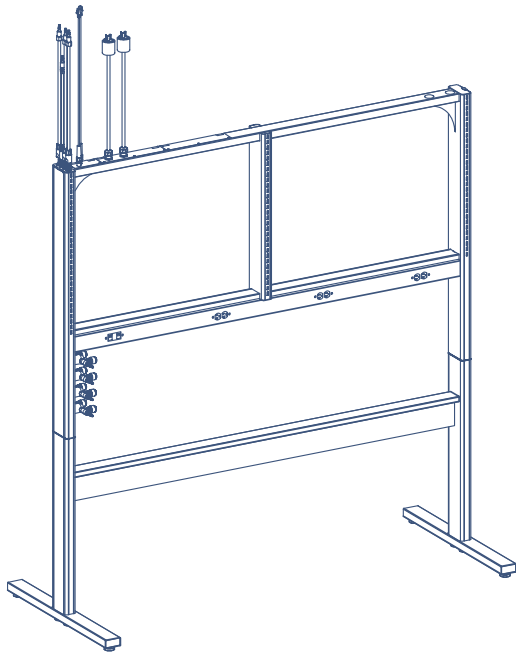

7 Full height Distribution Center installed on a free standing stand

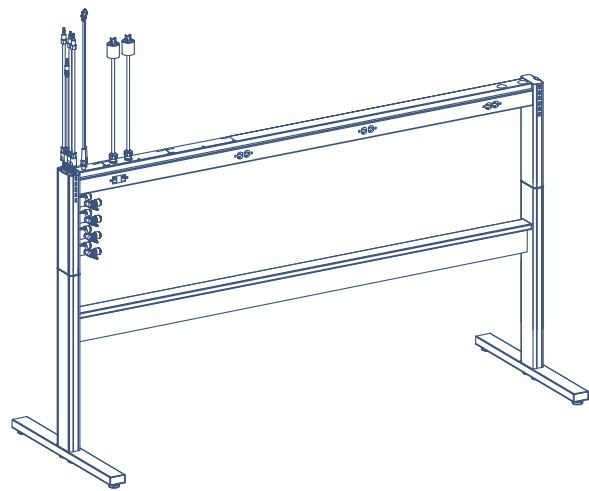

8 Low height Distribution Center installed on a free standing stand

System dimensions

US Patent no. D739,553

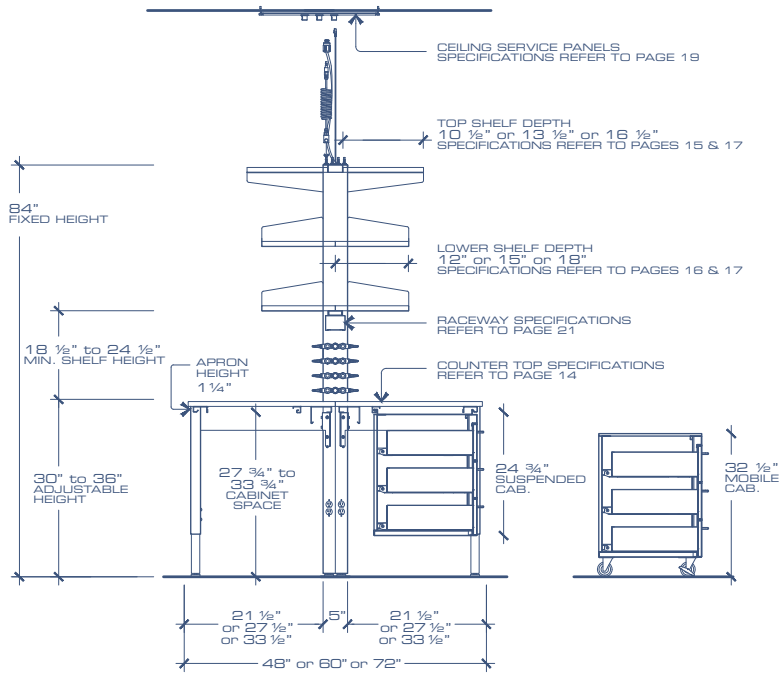

Double-sided table assembly with full-height Distribution Center

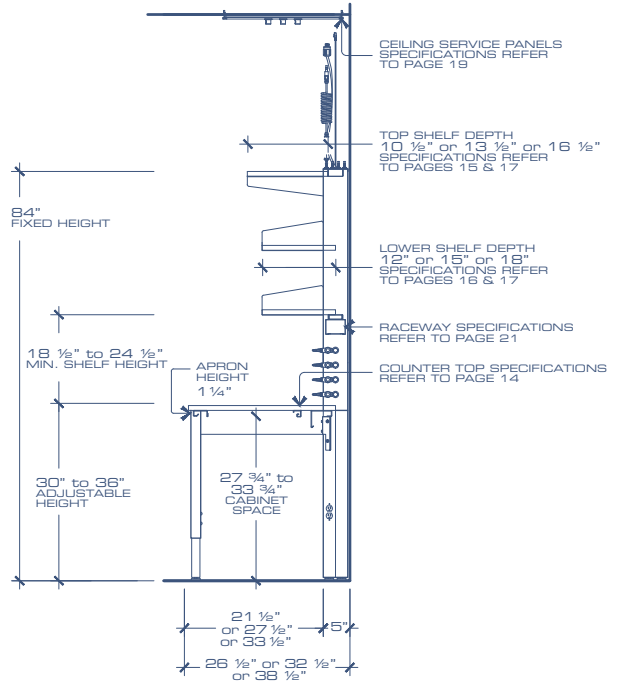

Single-sided table assembly with full-height Distribution Center

SYMPHONY II SYSTEM

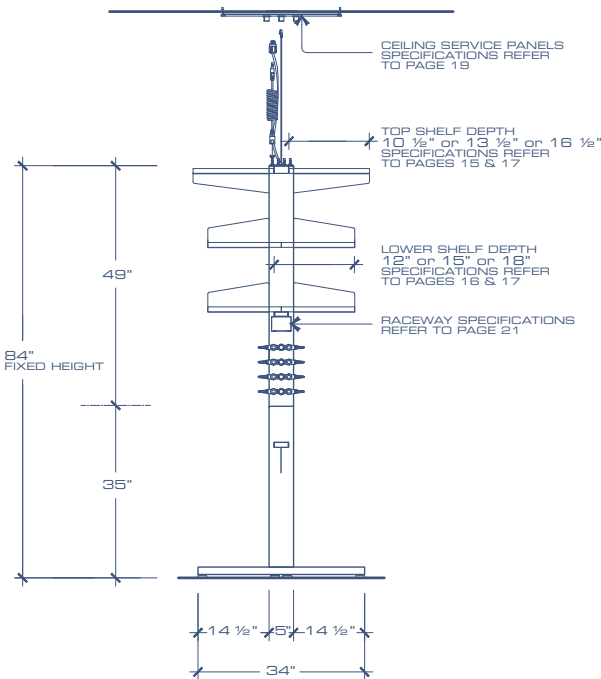

Full-height Distribution Center on a free standing stand

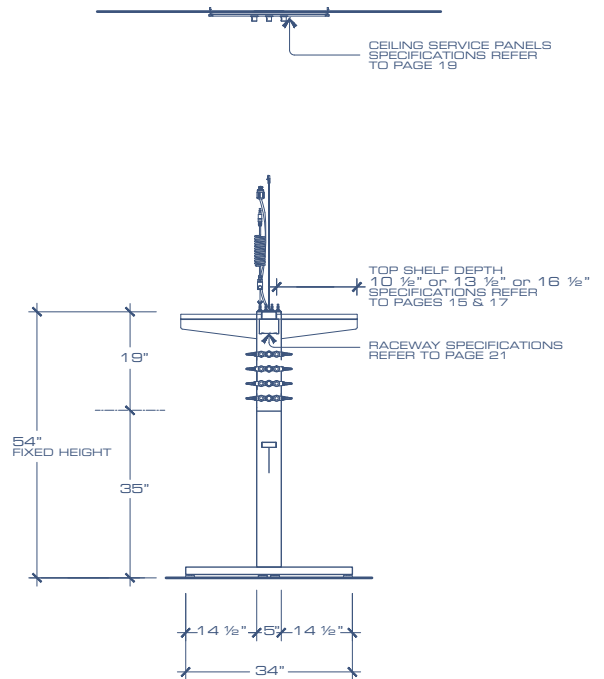

Low-height Distribution Center on a free standing stand

page 6

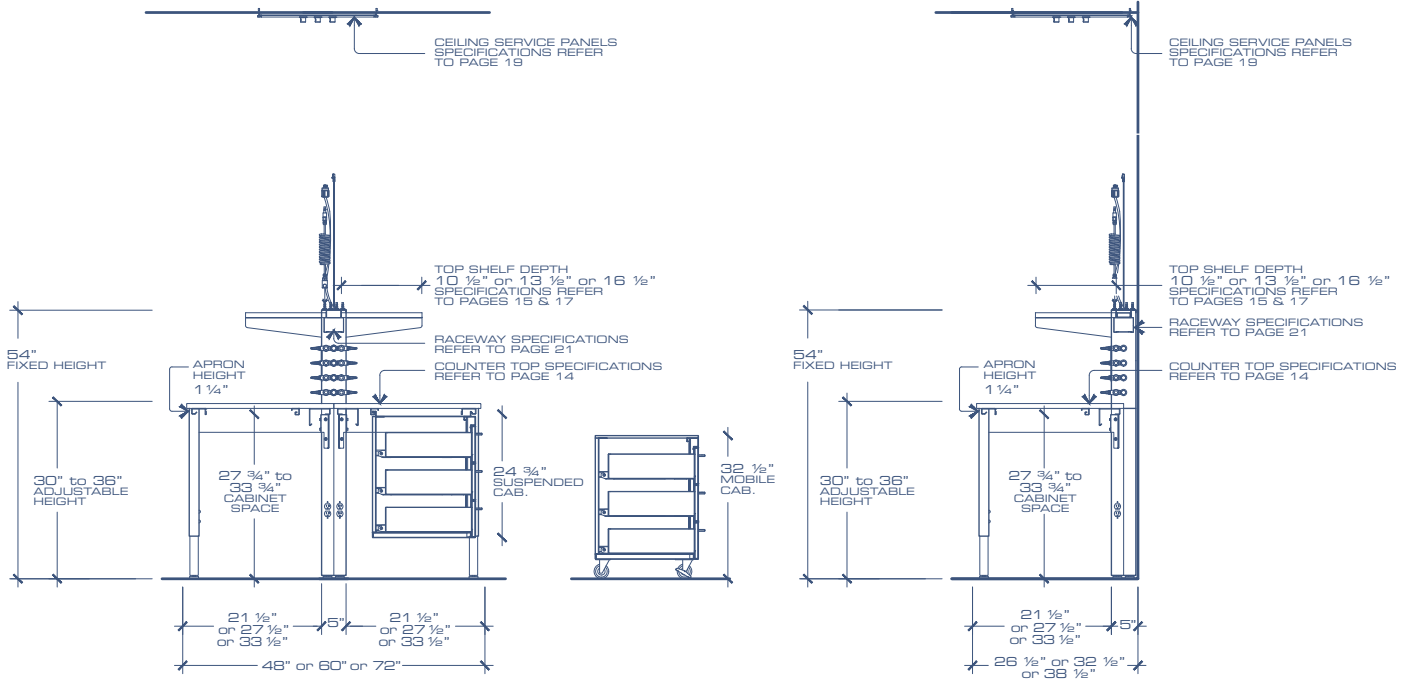

Double-sided table assembly with a low-height Distribution Center

Single-sided table assembly with a low-height Distribution Center

There are various cabinet options that can be integrated with the Symphony II system however the following three cabinet styles are more suitable to the system dimensions:

- ▶ Our 24 3/4" OB series suspended cabinets that follow the work surface heights from 30" to 36"
- ▶ Our ADA series cabinet height of 32 1/2" that fits under the table standing height of 36"
- ▶ Our B series cabinet height of 28 3/4" that fits the work surface heights from 30" to 36"

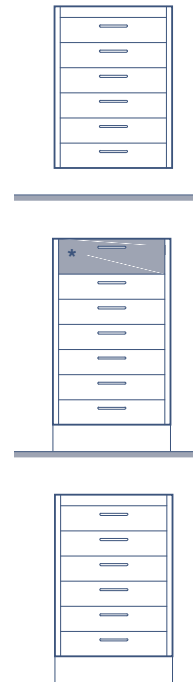

Each of these cabinets are available from our 3 lines of cabinets: Forte Inset, Forte Flush Overlay or Harmony.

Standard 60" deep double-sided Assemblies

US Patent no. D739,553

The underneath standard assemblies do not include any plumbing, electrical or data fixtures which need to be added to the double-sided table order sheet on page 25

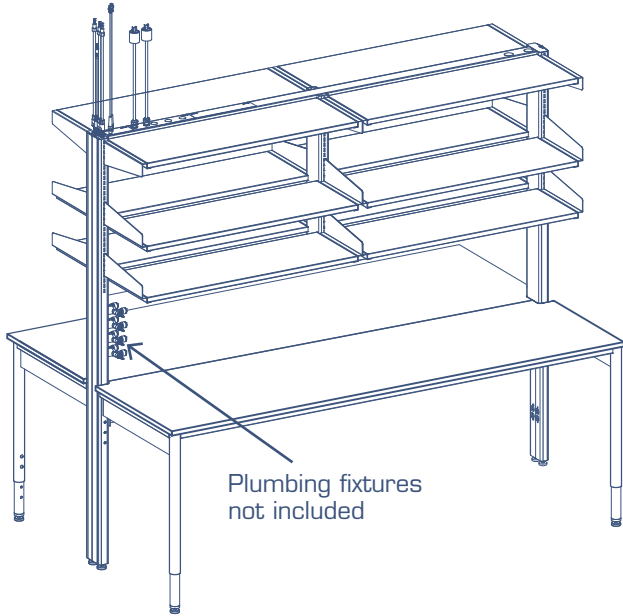

Plumbing fixtures not included

Double-sided Table Assemblies with full-height Distribution Center - 3 tier painted steel shelving included

MODEL NO.	WIDTH	DEPTH	HEIGHT
DSYM-3660	36"	60"	84"
DSYM-4260	42"	60"	84"
DSYM-4860	48"	60"	84"
DSYM-5460	54"	60"	84"
DSYM-6060	60"	60"	84"
DSYM-6660	66"	60"	84"
DSYM-7260	72"	60"	84"
DSYM-8460	84"	60"	84"
DSYM-9660	96"	60"	84"

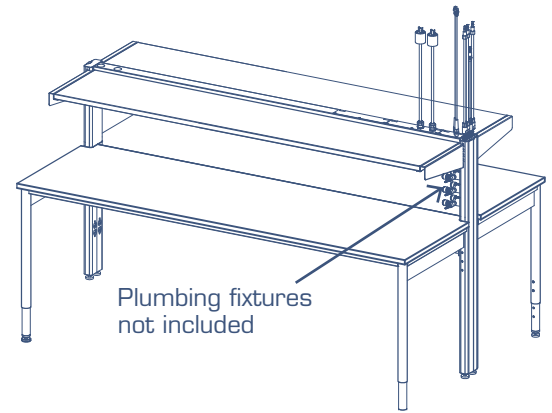

Plumbing fixtures not included

Double-sided Table Assemblies with low-height Distribution Center - 1-tier painted steel shelving included

MODEL NO.	WIDTH	DEPTH	HEIGHT
L-DSYM-3660	36"	60"	54"
L-DSYM-4260	42"	60"	54"
L-DSYM-4860	48"	60"	54"
L-DSYM-5460	54"	60"	54"
L-DSYM-6060	60"	60"	54"
L-DSYM-6660	66"	60"	54"
L-DSYM-7260	72"	60"	54"
L-DSYM-8460	84"	60"	54"
L-DSYM-9660	96"	60"	54"

Double-sided Table Assemblies with full-height Distribution Center - no shelves included

MODEL NO.	WIDTH	DEPTH	HEIGHT
DSY-3660	36"	60"	84"
DSY-4260	42"	60"	84"
DSY-4860	48"	60"	84"
DSY-5460	54"	60"	84"
DSY-6060	60"	60"	84"
DSY-6660	66"	60"	84"
DSY-7260	72"	60"	84"
DSY-8460	84"	60"	84"
DSY-9660	96"	60"	84"

Double-sided Table Assemblies with low-height Distribution Center - no shelves included

MODEL NO.	WIDTH	DEPTH	HEIGHT
L-DSY-3660	36"	60"	54"
L-DSY-4260	42"	60"	54"
L-DSY-4860	48"	60"	54"
L-DSY-5460	54"	60"	54"
L-DSY-6060	60"	60"	54"
L-DSY-6660	66"	60"	54"
L-DSY-7260	72"	60"	54"
L-DSY-8460	84"	60"	54"
L-DSY-9660	96"	60"	54"

Each assembly includes the table structure, the distribution center and the horizontal electrical raceway with three (3) duplex 120V/20A outlets and a one-circuit 4' cord with a twist lock plug L520P per side and one (1) Cat 6 data outlet with a 4' over the table extension per side. Counter tops and plumbing fixtures need to be specified on order sheets 27 and/or 28.

SYMPHONY II SYSTEM

page 8

The underneath standard assemblies do not include any plumbing, electrical or data fixtures which need to be added to the double-sided table order sheet on page 24

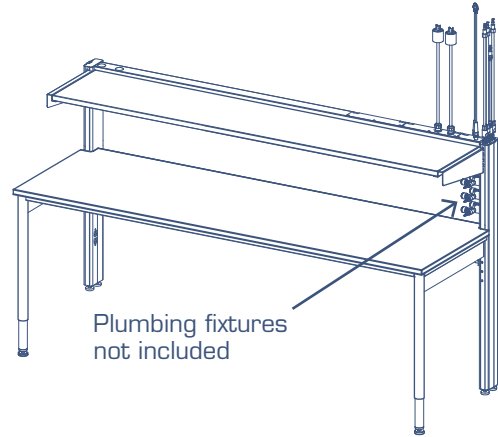
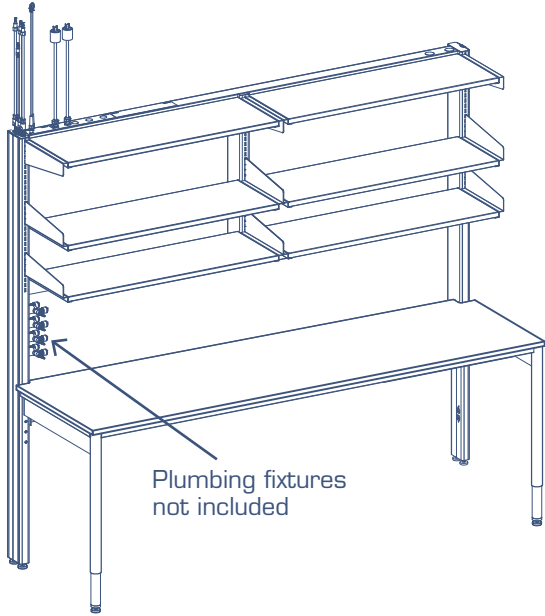

Single-sided Table Assemblies with full-height Distribution Center - 3-tier painted steel shelving included

Single-sided Table Assemblies with low-height Distribution Center - 1-tier painted steel shelving included

MODEL NO.	WIDTH	DEPTH	HEIGHT
SSYM-3660	36"	32,5"	84"
SSYM-4260	42"	32,5"	84"
SSYM-4860	48"	32,5"	84"
SSYM-5460	54"	32,5"	84"
SSYM-6060	60"	32,5"	84"
SSYM-6660	66"	32,5"	84"
SSYM-7260	72"	32,5"	84"
SSYM-8460	84"	32,5"	84"
SSYM-9660	96"	32,5"	84"

MODEL NO.	WIDTH	DEPTH	HEIGHT
L-SSYM-3660	36"	32,5"	54"
L-SSYM-4260	42"	32,5"	54"
L-SSYM-4860	48"	32,5"	54"
L-SSYM-5460	54"	32,5"	54"
L-SSYM-6060	60"	32,5"	54"
L-SSYM-6660	66"	32,5"	54"
L-SSYM-7260	72"	32,5"	54"
L-SSYM-8460	84"	32,5"	54"
L-SSYM-9660	96"	32,5"	54"

Single-sided Table Assemblies with full-height Distribution Center - no shelves included

Single-sided Table Assemblies with low-height Distribution Center - no shelves included

MODEL NO.	WIDTH	DEPTH	HEIGHT
SSY-3660	36"	32,5"	84"
SSY-4260	42"	32,5"	84"
SSY-4860	48"	32,5"	84"
SSY-5460	54"	32,5"	84"
SSY-6060	60"	32,5"	84"
SSY-6660	66"	32,5"	84"
SSY-7260	72"	32,5"	84"
SSY-8460	84"	32,5"	84"
SSY-9660	96"	32,5"	84"

MODEL NO.	WIDTH	DEPTH	HEIGHT
L-SSY-3660	36"	32,5"	54"
L-SSY-4260	42"	32,5"	54"
L-SSY-4860	48"	32,5"	54"
L-SSY-5460	54"	32,5"	54"
L-SSY-6060	60"	32,5"	54"
L-SSY-6660	66"	32,5"	54"
L-SSY-7260	72"	32,5"	54"
L-SSY-8460	84"	32,5"	54"
L-SSY-9660	96"	32,5"	54"

Each assembly includes the table structure, the distribution center and the horizontal electrical raceway with three (3) duplex 120V/20A outlets and a one-circuit 4' cord with a twist lock plug L52OP per side and one (1) Cat 6 data outlet with a 4' over the table extension per side. Counter tops and plumbing fixtures need to be specified on order sheets 27 and/or 28.

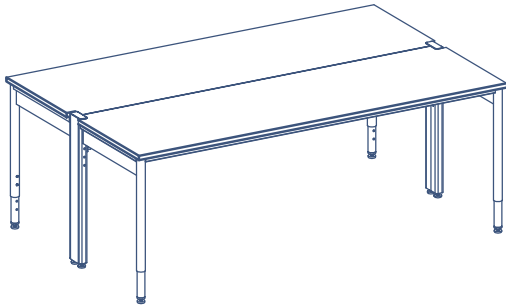

Height adjustable table assembly consisting of two all-welded structures each with two 2" diameter front legs, 1 1/4" high front apron and 4 7/8" high side aprons supplied with 2 double center legs 5" x 2"

Height adjustable double-sided tables - 30" to 36" in 2" increment

WIDTH	48" DEPTH	60" DEPTH	72" DEPTH
36"	DY-TA-3648	DY-TA-3660	DY-TA-3672
42"	DY-TA-4248	DY-TA-4260	DY-TA-4272
48"	DY-TA-4848	DY-TA-4860	DY-TA-4872
54"	DY-TA-5448	DY-TA-5460	DY-TA-5472
60"	DY-TA-6048	DY-TA-6060	DY-TA-6072
66"	DY-TA-6648	DY-TA-6660	DY-TA-6672
72"	DY-TA-7248	DY-TA-7260	DY-TA-7272
84"	DY-TA-8448	DY-TA-8460	DY-TA-8472
96"	DY-TA-9648	DY-TA-9660	DY-TA-9672

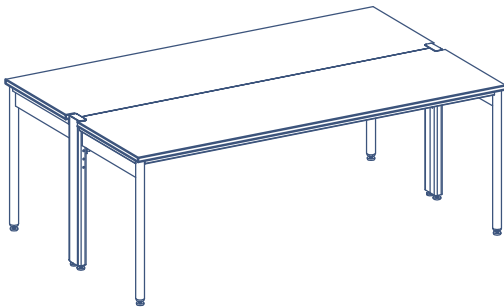

30" fixed height table assembly consisting of two all-welded structures each with two 2" diameter front legs, 1 1/4" high front apron and 4 7/8" high side aprons supplied with 2 double center legs 5" x 2"

Fixed 30" double-sided sitting height tables

WIDTH	48" DEPTH	60" DEPTH	72" DEPTH
36"	DY-TL-3648	DY-TL-3660	DY-TL-3672
42"	DY-TL-4248	DY-TL-4260	DY-TL-4272
48"	DY-TL-4848	DY-TL-4860	DY-TL-4872
54"	DY-TL-5448	DY-TL-5460	DY-TL-5472
60"	DY-TL-6048	DY-TL-6060	DY-TL-6072
66"	DY-TL-6648	DY-TL-6660	DY-TL-6672
72"	DY-TL-7248	DY-TL-7260	DY-TL-7272
84"	DY-TL-8448	DY-TL-8460	DY-TL-8472
96"	DY-TL-9648	DY-TL-9660	DY-TL-9672

36" fixed height table assembly consisting of two all-welded structures each with two 2" diameter front legs, 1 1/4" high front apron and 4 7/8" high side aprons supplied with 2 double center legs 5" x 2"

Fixed 36" double-sided standing height tables

WIDTH	48" DEPTH	60" DEPTH	72" DEPTH
36"	DY-TH-3648	DY-TH-3660	DY-TH-3672
42"	DY-TH-4248	DY-TH-4260	DY-TH-4272
48"	DY-TH-4848	DY-TH-4860	DY-TH-4872
54"	DY-TH-5448	DY-TH-5460	DY-TH-5472
60"	DY-TH-6048	DY-TH-6060	DY-TH-6072
66"	DY-TH-6648	DY-TH-6660	DY-TH-6672
72"	DY-TH-7248	DY-TH-7260	DY-TH-7272
84"	DY-TH-8448	DY-TH-8460	DY-TH-8472
96"	DY-TH-9648	DY-TH-9660	DY-TH-9672

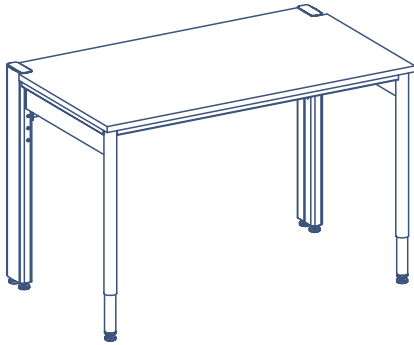

Height adjustable table assembly consisting on an all-welded structure with two 2" diameter front legs, 1 1/4" high front apron and 4 7/8" high sides aprons supplied with 2 double back legs 5" x 2"

Height adjustable single-sided tables - 30" to 36" in 2" increment

WIDTH	24" DEPTH	30" DEPTH	36" DEPTH
36"	SY-TA-3624	SY-TA-3630	SY-TA-3636
42"	SY-TA-4224	SY-TA-4230	SY-TA-4236
48"	SY-TA-4824	SY-TA-4830	SY-TA-4836
54"	SY-TA-5424	SY-TA-5430	SY-TA-5436
60"	SY-TA-6024	SY-TA-6030	SY-TA-6036
66"	SY-TA-6624	SY-TA-6630	SY-TA-6636
72"	SY-TA-7224	SY-TA-7230	SY-TA-7236
84"	SY-TA-8424	SY-TA-8430	SY-TA-8436
96"	SY-TA-9624	SY-TA-9630	SY-TA-9636

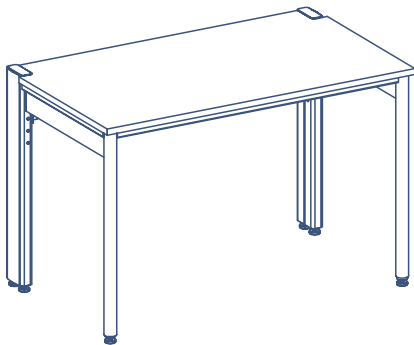

Fixed 30" height table assembly consisting on an all-welded structure with two 2" diameter front legs, 1 1/4" high front apron and 4 7/8" high sides aprons supplied with 2 double back legs 5" x 2"

Fixed 36" standing height single-sided tables

WIDTH	24" DEPTH	30" DEPTH	36" DEPTH
36"	SY-TL-3624	SY-TL-3630	SY-TL-3636
42"	SY-TL-4224	SY-TL-4230	SY-TL-4236
48"	SY-TL-4824	SY-TL-4830	SY-TL-4836
54"	SY-TL-5424	SY-TL-5430	SY-TL-5436
60"	SY-TL-6024	SY-TL-6030	SY-TL-6036
66"	SY-TL-6624	SY-TL-6630	SY-TL-6636
72"	SY-TL-7224	SY-TL-7230	SY-TL-7236
84"	SY-TL-8424	SY-TL-8430	SY-TL-8436
96"	SY-TL-9624	SY-TL-9630	SY-TL-9636

Fixed 36" height table assembly consisting on an all-welded structure with two 2" diameter front legs, 1 1/4" high front apron and 4 7/8" high sides aprons supplied with 2 double back legs 5" x 2"

Fixed 36" double-sided standing height tables

WIDTH	24" DEPTH	30" DEPTH	36" DEPTH
36"	SY-TH-3624	SY-TH-3630	SY-TH-3636
42"	SY-TH-4224	SY-TH-4230	SY-TH-4236
48"	SY-TH-4824	SY-TH-4830	SY-TH-4836
54"	SY-TH-5424	SY-TH-5430	SY-TH-5436
60"	SY-TH-6024	SY-TH-6030	SY-TH-6036
66"	SY-TH-6624	SY-TH-6630	SY-TH-6636
72"	SY-TH-7224	SY-TH-7230	SY-TH-7236
84"	SY-TH-8424	SY-TH-8430	SY-TH-8436
96"	SY-TH-9624	SY-TH-9630	SY-TH-9636

Distribution centers

The underneath Distribution Centers do not include any plumbing, electrical or data fixtures which need to be added on the order sheet of pages 24 and 25

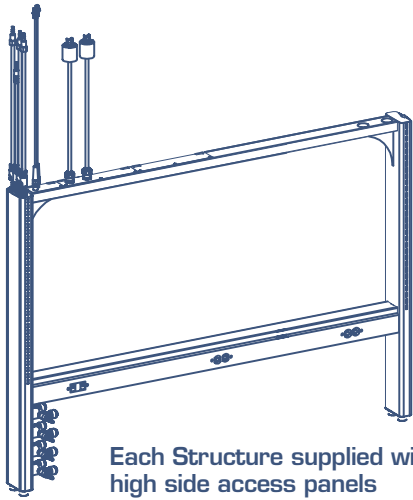

Each Structure supplied with two full 84" high side access panels

Full height Distribution Center – designed to houses all services and shelving

MODEL NO.	WIDTH	DEPTH	HEIGHT
SY-DC-36	36"	5"	49"
SY-DC-42	42"	5"	49"
SY-DC-48	48"	5"	49"

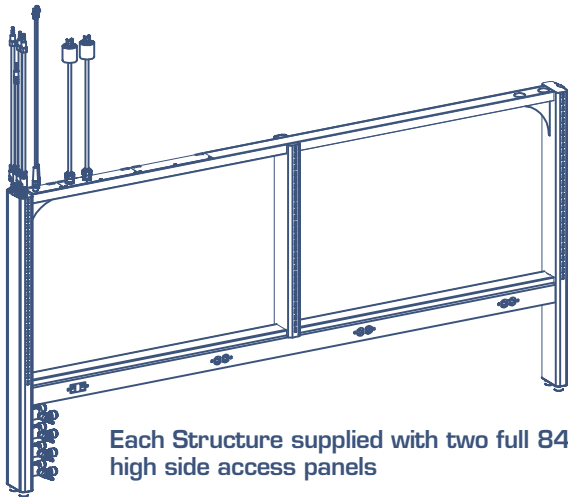

Each Structure supplied with two full 84" high side access panels

Full height Distribution Center – designed to houses all services and shelving

MODEL NO.	WIDTH	DEPTH	HEIGHT
SY-DC-54	54"	5"	49"
SY-DC-60	60"	5"	49"
SY-DC-66	66"	5"	49"
SY-DC-72	72"	5"	49"
SY-DC-84	84"	5"	49"
SY-DC-96	96"	5"	49"

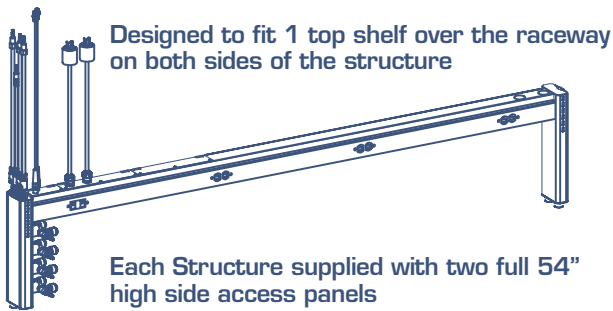

Designed to fit 1 top shelf over the raceway on both sides of the structure

Each Structure supplied with two full 54" high side access panels

Low height Distribution Center – designed to houses all services and 1-tier shelving

MODEL NO.	WIDTH	DEPTH	HEIGHT
SY-DL-36	36"	5"	19"
SY-DL-42	42"	5"	19"
SY-DL-48	48"	5"	19"
SY-DL-54	54"	5"	19"
SY-DL-60	60"	5"	19"
SY-DL-66	66"	5"	19"
SY-DL-72	72"	5"	19"
SY-DL-84	84"	5"	19"
SY-DL-96	96"	5"	19"

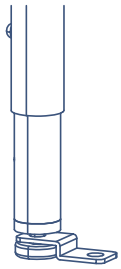

SY-SB-1 bracket to be used during installation



SY-SB-2 bracket to be used after installation



Table seismic brackets (for table anchoring to the floor)

MODEL NO.	DESCRIPTION
SY-SB-1	Closed bracket to be used during installation
SY-SB-2	Open bracket to be used during construction

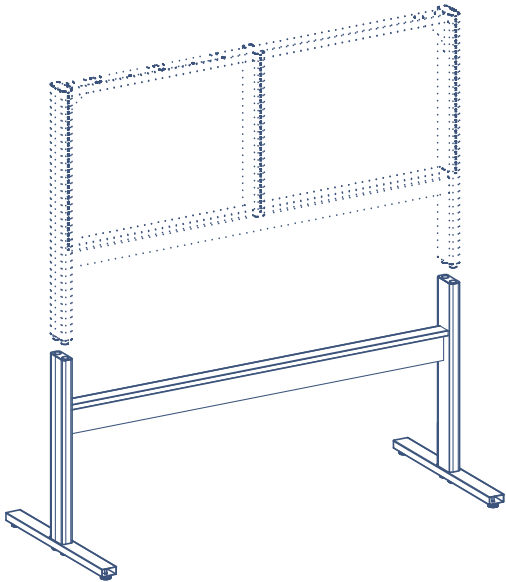

Free Standing Distribution Center Stand

MODEL NO.	WIDTH	DEPTH	HEIGHT
SY-DS-36	36"	5"	35"
SY-DS-42	42"	5"	35"
SY-DS-48	48"	5"	35"
SY-DS-54	54"	5"	35"
SY-DS-60	60"	5"	35"
SY-DS-66	66"	5"	35"
SY-DS-72	72"	5"	35"
SY-DS-84	84"	5"	35"
SY-DS-96	96"	5"	35"



Gas type must be indicated on specification sheets 23, 24 or 25



Stand alone plumbing service upright

MODEL NO.	WIDTH	DEPTH	HEIGHT	# OF SERVICES
SY-UP-1	2"	5"	49"	1 x gas
SY-UP-2	2"	5"	49"	2 x gases
SY-UP-3	2"	5"	49"	3 x gases
SY-UP-4	2"	5"	49"	4 x gases

Stand alone electrical service upright - 120V/20A duplex outlet(s)

MODEL NO.	WIDTH	DEPTH	HEIGHT	# OF SERVICES
SY-UE-1	2"	5"	49"	1 x elect.
SY-UE-2	2"	5"	49"	2 x elect.
SY-UE-3	2"	5"	49"	3 x elect.
SY-UE-4	2"	5"	49"	4 x elect.

Stand alone electrical/data service upright - 120V/20A duplex outlet(s) + T6A data outlet(s)

MODEL NO.	WIDTH	DEPTH	HEIGHT	# OF SERVICES
SY-UD-1	2"	5"	49"	1 x elect. + 1 data
SY-UD-2	2"	5"	49"	2 x elect. + 1 data
SY-UD-3	2"	5"	49"	3 x elect. + 2 data
SY-UD-4	2"	5"	49"	3 x elect. + 3 data

Add-a-leg tables

The underneath tables are complement tables to be used as stand-alone units into a Symphony system project

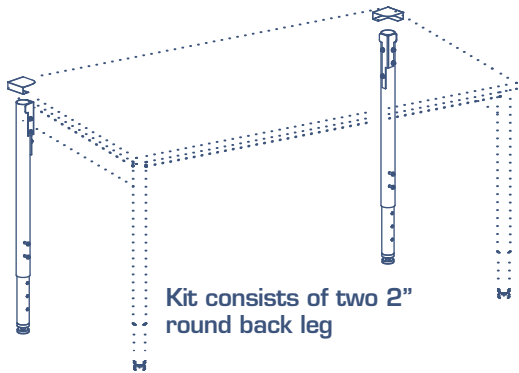

Kit consists of two 2" round back leg

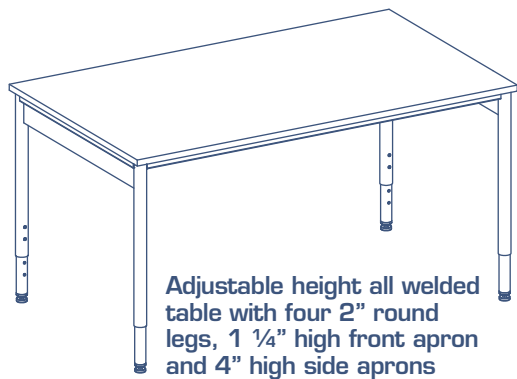

Adjustable height all welded table with four 2" round legs, 1 1/4" high front apron and 4" high side aprons

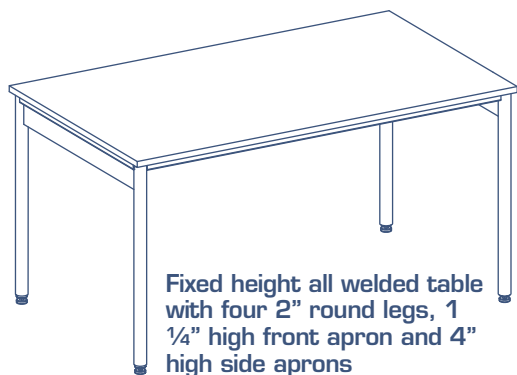

Fixed height all welded table with four 2" round legs, 1 1/4" high front apron and 4" high side aprons

Add-a-leg kits (added to the back of any work surface structures to form a 4-leg table) - no counter tops included

MODEL NO.	LEG SIZE	TABLE HEIGHT
SY-AK-A	2" diameter	Adjustable from 30" to 36"
SY-AK-L	2" diameter	fixed at 30"
SY-AK-H	2" diameter"	fixed at 36"

Height adjustable add-a-leg tables - 30" to 36" in 2" increment - no counter tops included

WIDTH	24" DEPTH	30" DEPTH	36" DEPTH
36"	SY-AT-3624	SY-AT-3630	SY-AT-3636
42"	SY-AT-4224	SY-AT-4230	SY-AT-4236
48"	SY-AT-4824	SY-AT-4830	SY-AT-4836
54"	SY-AT-5424	SY-AT-5430	SY-AT-5436
60"	SY-AT-6024	SY-AT-6030	SY-AT-6036
66"	SY-AT-6624	SY-AT-6630	SY-AT-6636
72"	SY-AT-7224	SY-AT-7230	SY-AT-7236
84"	SY-AT-8424	SY-AT-8430	SY-AT-8436
96"	SY-AT-9624	SY-AT-9630	SY-AT-9636

Fixed 30" sitting height add-a-leg tables - no counter tops included

WIDTH	24" DEPTH	30" DEPTH	36" DEPTH
36"	SY-AL-3624	SY-AL-3630	SY-AL-3636
42"	SY-AL-4224	SY-AL-4230	SY-AL-4236
48"	SY-AL-4824	SY-AL-4830	SY-AL-4836
54"	SY-AL-5424	SY-AL-5430	SY-AL-5436
60"	SY-AL-6024	SY-AL-6030	SY-AL-6036
66"	SY-AL-6624	SY-AL-6630	SY-AL-6636
72"	SY-AL-7224	SY-AL-7230	SY-AL-7236
84"	SY-AL-8424	SY-AL-8430	SY-AL-8436
96"	SY-AL-9624	SY-AL-9630	SY-AL-9636

Fixed 36" standing height add-a-leg tables - no counter tops included

WIDTH	24" DEPTH	30" DEPTH	36" DEPTH
36"	SY-AH-3624	SY-AH-3630	SY-AH-3636
42"	SY-AH-4224	SY-AH-4230	SY-AH-4236
48"	SY-AH-4824	SY-AH-4830	SY-AH-4836
54"	SY-AH-5424	SY-AH-5430	SY-AH-5436
60"	SY-AH-6024	SY-AH-6030	SY-AH-6036
66"	SY-AH-6624	SY-AH-6630	SY-AH-6636
72"	SY-AH-7224	SY-AH-7230	SY-AH-7236
84"	SY-AH-8424	SY-AH-8430	SY-AH-8436
96"	SY-AH-9624	SY-AH-9630	SY-AH-9636

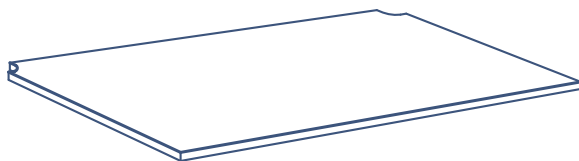

1" thick counter tops that fit the system table structure (with 2 back corner clots)

WIDTH	Black epoxy resin			Phenolic (from standard colors)		
	24" DEPTH	30" DEPTH	36" DEPTH	24" DEPTH	30" DEPTH	36" DEPTH
36"	SY-CTE-3624	SY-CTE-3630	SY-CTE-3636	SY-CTP-3624	SY-CTP-3630	SY-CTP-3636
42"	SY-CTE-4224	SY-CTE-4230	SY-CTE-4236	SY-CTP-4224	SY-CTP-4230	SY-CTP-4236
48"	SY-CTE-4824	SY-CTE-4830	SY-CTE-4836	SY-CTP-4824	SY-CTP-4830	SY-CTP-4836
54"	SY-CTE-5424	SY-CTE-5430	SY-CTE-5436	SY-CTP-5424	SY-CTP-5430	SY-CTP-5436
60"	SY-CTE-6024	SY-CTE-6030	SY-CTE-6036	SY-CTP-6024	SY-CTP-6030	SY-CTP-6036
66"	SY-CTE-6624	SY-CTE-6630	SY-CTE-6636	SY-CTP-6624	SY-CTP-6630	SY-CTP-6636
72"	SY-CTE-7224	SY-CTE-7230	SY-CTE-7236	SY-CTP-7224	SY-CTP-7230	SY-CTP-7236
84"	SY-CTE-8424	SY-CTE-8430	SY-CTE-8436	SY-CTP-8424	SY-CTP-8430	SY-CTP-8436
96"	SY-CTE-9624	SY-CTE-9630	SY-CTE-9636	SY-CTP-9624	SY-CTP-9630	SY-CTP-9636

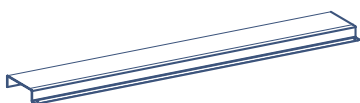

2 1/2" painted steel spacer for single-sided table counter tops (fill the space between the counter top back and the wall)

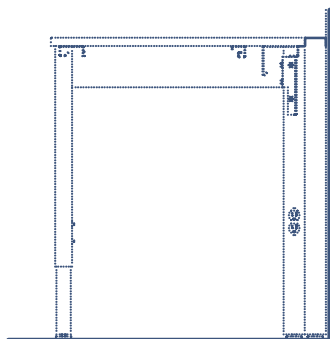

MODEL NO.	WIDTH	DEPTH	HEIGHT
SY-ST-36	36"	2,5"	1"
SY-ST-42	42"	2,5"	1"
SY-ST-48	48"	2,5"	1"
SY-ST-54	54"	2,5"	1"
SY-ST-60	60"	2,5"	1"
SY-ST-66	66"	2,5"	1"
SY-ST-72	72"	2,5"	1"
SY-ST-84	84"	2,5"	1"
SY-ST-96	96"	2,5"	1"

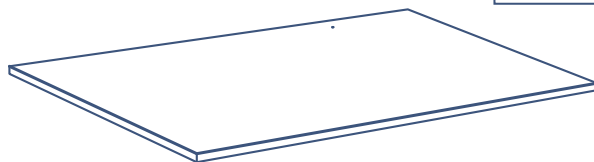

1" thick counter tops that fit all add-a-leg tables.

WIDTH	Black epoxy resin			Phenolic (from standard colors)		
	24" DEPTH	30" DEPTH	36" DEPTH	24" DEPTH	30" DEPTH	36" DEPTH
36"	SY-CFE-3624	SY-CFE-3630	SY-CFE-3636	SY-CFP-3624	SY-CFP-3630	SY-CFP-3636
42"	SY-CFE-4224	SY-CFE-4230	SY-CFE-4236	SY-CFP-4224	SY-CFP-4230	SY-CFP-4236
48"	SY-CFE-4824	SY-CFE-4830	SY-CFE-4836	SY-CFP-4824	SY-CFP-4830	SY-CFP-4836
54"	SY-CFE-5424	SY-CFE-5430	SY-CFE-5436	SY-CFP-5424	SY-CFP-5430	SY-CFP-5436
60"	SY-CFE-6024	SY-CFE-6030	SY-CFE-6036	SY-CFP-6024	SY-CFP-6030	SY-CFP-6036
66"	SY-CFE-6624	SY-CFE-6630	SY-CFE-6636	SY-CFP-6624	SY-CFP-6630	SY-CFP-6636
72"	SY-CFE-7224	SY-CFE-7230	SY-CFE-7236	SY-CFP-7224	SY-CFP-7230	SY-CFP-7236
84"	SY-CFE-8424	SY-CFE-8430	SY-CFE-8436	SY-CFP-8424	SY-CFP-8430	SY-CFP-8436
96"	SY-CFE-9624	SY-CFE-9630	SY-CFE-9636	SY-CFP-9624	SY-CFP-9630	SY-CFP-9636

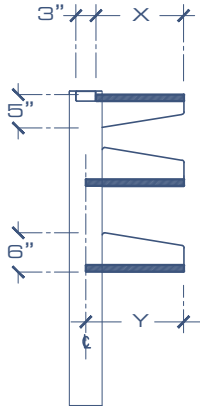

Available shelving depths

Lower shelf depth "Y"	Top shelf corresponding depth "X"
12"	10 1/2"
15"	13 1/2"
18"	16 1/2"

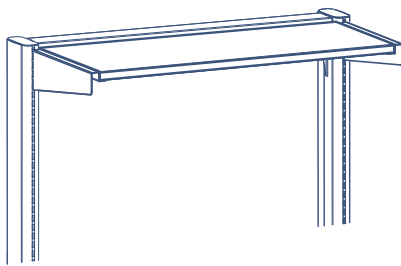

Top Shelf assemblies (1 shelf and 2 bookend brackets)

Bench Width	Shelf depth	Shelf thickness	Painted steel	Maple Wood	Plastic laminate	Phenolic
36"	10,5"	1"	SY-UM-3610	SY-UW-3610	SY-UL-3610	SY-UP-3610
	13,5"	1"	SY-UM-3613	SY-UW-3613	SY-UL-3613	SY-UP-3613
	16,5"	1"	SY-UM-3616	SY-UW-3616	SY-UL-3616	SY-UP-3616
42"	10,5"	1"	SY-UM-4210	SY-UW-4210	SY-UL-4210	SY-UP-4210
	13,5"	1"	SY-UM-4213	SY-UW-4213	SY-UL-4213	SY-UP-4213
	16,5"	1"	SY-UM-4216	SY-UW-4216	SY-UL-4216	SY-UP-4216
48"	10,5"	1"	SY-UM-4810	SY-UW-4810	SY-UL-4810	SY-UP-4810
	13,5"	1"	SY-UM-4813	SY-UW-4813	SY-UL-4813	SY-UP-4813
	16,5"	1"	SY-UM-4816	SY-UW-4816	SY-UL-4816	SY-UP-4816

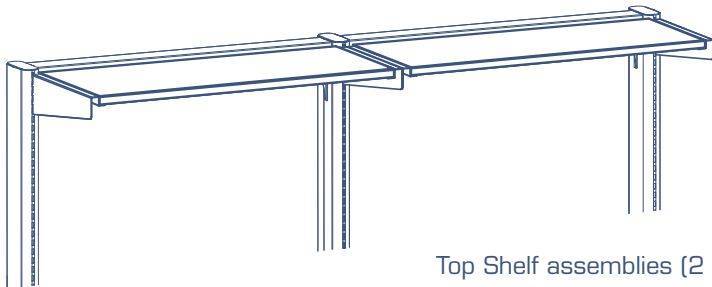

Top Shelf assemblies (2 shelves and 4 bookend brackets)

Bench Width	Shelf depth	Shelf thickness	Painted steel	Maple Wood	Plastic laminate	Phenolic
54"	10,5"	1"	SY-UM-5410	SY-UW-5410	SY-UL-5410	SY-UP-5410
	13,5"	1"	SY-UM-5413	SY-UW-5413	SY-UL-5413	SY-UP-5413
	16,5"	1"	SY-UM-5416	SY-UW-5416	SY-UL-5416	SY-UP-5416
60"	10,5"	1"	SY-UM-6010	SY-UW-6010	SY-UL-6010	SY-UP-6010
	13,5"	1"	SY-UM-6013	SY-UW-6013	SY-UL-6013	SY-UP-6013
	16,5"	1"	SY-UM-6016	SY-UW-6016	SY-UL-6016	SY-UP-6016
72"	10,5"	1"	SY-UM-7210	SY-UW-7210	SY-UL-7210	SY-UP-7210
	13,5"	1"	SY-UM-7213	SY-UW-7213	SY-UL-7213	SY-UP-7213
	16,5"	1"	SY-UM-7216	SY-UW-7216	SY-UL-7216	SY-UP-7216
84"	10,5"	1"	SY-UM-8410	SY-UW-8410	SY-UL-8410	SY-UP-8410
	13,5"	1"	SY-UM-8413	SY-UW-8413	SY-UL-8413	SY-UP-8413
	16,5"	1"	SY-UM-8416	SY-UW-8416	SY-UL-8416	SY-UP-8416
96"	10,5"	1"	SY-UM-9610	SY-UW-9610	SY-UL-9610	SY-UP-9610
	13,5"	1"	SY-UM-9613	SY-UW-9613	SY-UL-9613	SY-UP-9613
	16,5"	1"	SY-UM-9616	SY-UW-9616	SY-UL-9616	SY-UP-9616

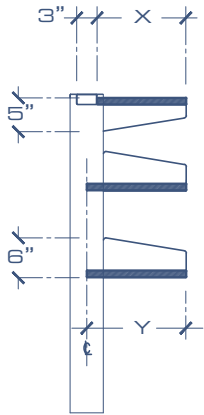

Available shelving depths

Lower shelf depth "Y"	Top shelf corresponding depth "X"
12"	10 ½"
15"	13 ½"
18"	16 ½"

Middle and bottom shelf assemblies (1 shelf and 2 bookend brackets)

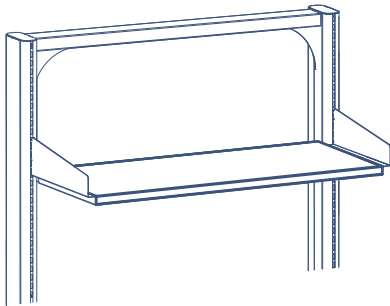

Bench Width	Shelf depth	Shelf thickness	Painted steel	Maple Wood	Plastic laminate	Phenolic
36"	12"	1"	SY-LM-3612	SY-LW-3612	SY-LL-3612	SY-LP-3612
	15"	1"	SY-LM-3615	SY-LW-3615	SY-LL-3615	SY-LP-3615
	18"	1"	SY-LM-3618	SY-LW-3618	SY-LL-3618	SY-LP-3618
42"	12"	1"	SY-LM-4212	SY-LW-4212	SY-LL-4212	SY-LP-4212
	15"	1"	SY-LM-4215	SY-LW-4215	SY-LL-4215	SY-LP-4215
	18"	1"	SY-LM-4218	SY-LW-4218	SY-LL-4218	SY-LP-4218
48"	12"	1"	SY-LM-4812	SY-LW-4812	SY-LL-4812	SY-LP-4812
	15"	1"	SY-LM-4815	SY-LW-4815	SY-LL-4815	SY-LP-4815
	18"	1"	SY-LM-4818	SY-LW-4818	SY-LL-4818	SY-LP-4818

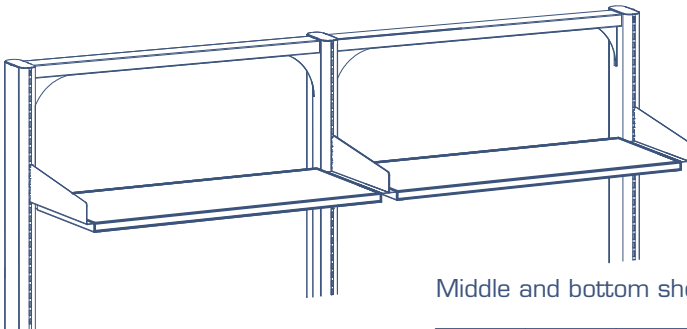

Middle and bottom shelf assemblies (2 shelves and 4 bookend brackets)

Bench Width	Shelf depth	Shelf thickness	Painted steel	Maple Wood	Plastic laminate	Phenolic
54"	12"	1"	SY-LM-5412	SY-LW-5412	SY-LL-5412	SY-LP-5412
	15"	1"	SY-LM-5415	SY-LW-5415	SY-LL-5415	SY-LP-5415
	18"	1"	SY-LM-5418	SY-LW-5418	SY-LL-5418	SY-LP-5418
60"	12"	1"	SY-LM-6012	SY-LW-6012	SY-LL-6012	SY-LP-6012
	15"	1"	SY-LM-6015	SY-LW-6015	SY-LL-6015	SY-LP-6015
	18"	1"	SY-LM-6018	SY-LW-6018	SY-LL-6018	SY-LP-6018
72"	12"	1"	SY-LM-7212	SY-LW-7212	SY-LL-7212	SY-LP-7212
	15"	1"	SY-LM-7215	SY-LW-7215	SY-LL-7215	SY-LP-7215
	18"	1"	SY-LM-7218	SY-LW-7218	SY-LL-7218	SY-LP-7218
84"	12"	1"	SY-LM-8412	SY-LW-8412	SY-LL-8412	SY-LP-8412
	15"	1"	SY-LM-8415	SY-LW-8415	SY-LL-8415	SY-LP-8415
	18"	1"	SY-LM-8418	SY-LW-8418	SY-LL-8418	SY-LP-8418
96"	12"	1"	SY-LM-9612	SY-LW-9612	SY-LL-9612	SY-LP-9612
	15"	1"	SY-LM-9615	SY-LW-9615	SY-LL-9615	SY-LP-9615
	18"	1"	SY-LM-9618	SY-LW-9618	SY-LL-9618	SY-LP-9618

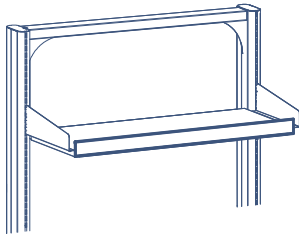

Front painted steel shelf retainer angles

Model no.	Table width	Angle depth	Angle height	Qty of angles per kit
SY-A1-36	36"	1"	2"	1
SY-A1-42	42"	1"	2"	1
SY-A1-48	48"	1"	2"	1
SY-A1-54	54"	1"	2"	2
SY-A1-60	60"	1"	2"	2
SY-A1-66	66"	1"	2"	2
SY-A1-72	72"	1"	2"	2
SY-A1-84	84"	1"	2"	2
SY-A1-96	96"	1"	2"	2

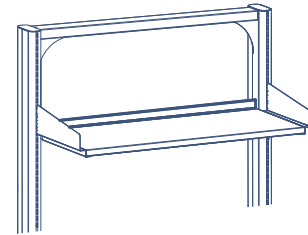

Back painted steel shelf retainer angles

Model no.	Table width	Angle depth	Angle height	Qty of angles per kit
SY-A2-36	36"	1"	2"	1
SY-A2-42	42"	1"	2"	1
SY-A2-48	48"	1"	2"	1
SY-A2-54	54"	1"	2"	2
SY-A2-60	60"	1"	2"	2
SY-A2-66	66"	1"	2"	2
SY-A2-72	72"	1"	2"	2
SY-A2-84	84"	1"	2"	2
SY-A2-96	96"	1"	2"	2

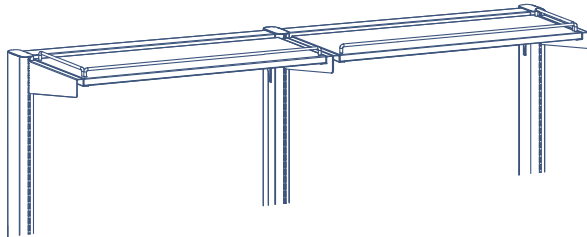

Top shelf - side retaining rods using 1/4" type 304 stainless steel rods

Model no.	Table width	Angle depth	Angle height	Qty of rods/kit
SY-R1-10	10,5"	0,25"	1,5"	2
SY-R1-14	14,5"	0,25"	1,5"	2
SY-R1-16	16,5"	0,25"	1,5"	2

Top shelf - front retaining rods using 1/4" type 304 stainless steel rods

Model no.	Table width	Angle depth	Angle height	Qty of rods/kit
SY-R2-36	36"	0,25"	1,5"	1
SY-R2-42	42"	0,25"	1,5"	1
SY-R2-48	48"	0,25"	1,5"	1
SY-R2-54	54"	0,25"	1,5"	2
SY-R2-60	60"	0,25"	1,5"	2
SY-R2-66	66"	0,25"	1,5"	2
SY-R2-72	72"	0,25"	1,5"	2
SY-R2-84	84"	0,25"	1,5"	2
SY-R2-96	96"	0,25"	1,5"	2

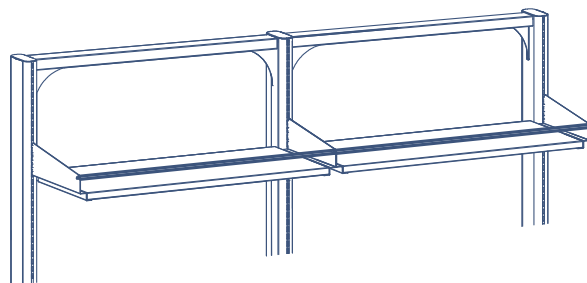

Bottom shelf - front retaining rods between shelf supports using 1/4" type 304 stainless steel rods

Model no.	Table width	Angle depth	Angle height	Qty of rods/kit
SY-R3-36	36"	0,25"	1,5"	1
SY-R3-42	42"	0,25"	1,5"	1
SY-R3-48	48"	0,25"	1,5"	1
SY-R3-54	54"	0,25"	1,5"	2
SY-R3-60	60"	0,25"	1,5"	2
SY-R3-66	66"	0,25"	1,5"	2
SY-R3-72	72"	0,25"	1,5"	2
SY-R3-84	84"	0,25"	1,5"	2
SY-R3-96	96"	0,25"	1,5"	2

Wall cabinet support bracket kits including top and bottom rails - made to support wall cabinets in lieu of open shelving on the upright structure – will fit any of our 24” or 30” high wall cabinets listed in our casework catalogues

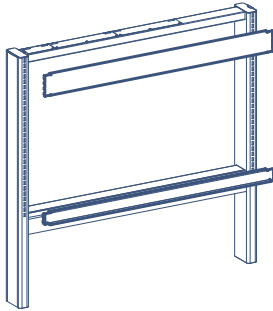

Model no.	Table width	Qty of tackboard
SY-W1-36	36"	1
SY-W1-42	42"	1
SY-W1-48	48"	1
SY-W1-54	54"	2
SY-W1-60	60"	2
SY-W1-66	66"	2
SY-W1-72	72"	2
SY-W1-84	84"	2
SY-W1-96	96"	2

Double-sided ¾” thick grey 14” high linoleum tack board with top and bottom painted steel angle support

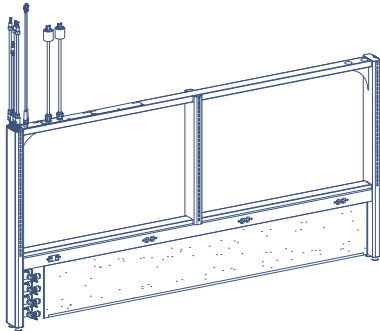

Full table width between uprights

Model no.	Table width	Qty of support kits per unit
SY-T1-36	36"	1
SY-T1-42	42"	1
SY-T1-48	48"	1
SY-T1-54	54"	1
SY-T1-60	60"	1
SY-T1-66	66"	1
SY-T1-72	72"	1
SY-T1-84	84"	1
SY-T1-96	96"	1

Full table width less plumbing fixture space

Model no.	Table width	Qty of tackboard
SY-T2-36	36"	1
SY-T2-42	42"	1
SY-T2-48	48"	1
SY-T2-54	54"	1
SY-T2-60	60"	1
SY-T2-66	66"	1
SY-T2-72	72"	1
SY-T2-84	84"	1
SY-T2-96	96"	1

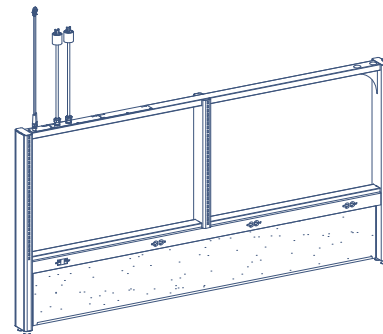

Clear ¼” Plexiglas sheet centered into the Distribution center to create a divider between shelving

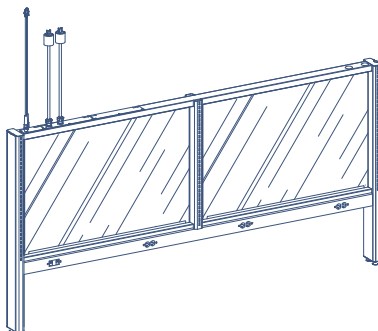

Model no.	Table width	Qty of tackboard
SY-T3-36	36"	1
SY-T3-42	42"	1
SY-T3-48	48"	1
SY-T3-54	54"	2
SY-T3-60	60"	2
SY-T3-66	66"	2
SY-T3-72	72"	2
SY-T3-84	84"	2
SY-T3-96	96"	2

Plumbing services

US Patent no. D739,553

The Symphony table is designed to integrate up to four (4) Plumbing fixtures per table – It is normally supply with single fixtures on the single-sided table and double fixtures on the double-sided table.

Please indicate the plumbing requirements on the Order sheets on pages 24 and/or 25 of this catalog.

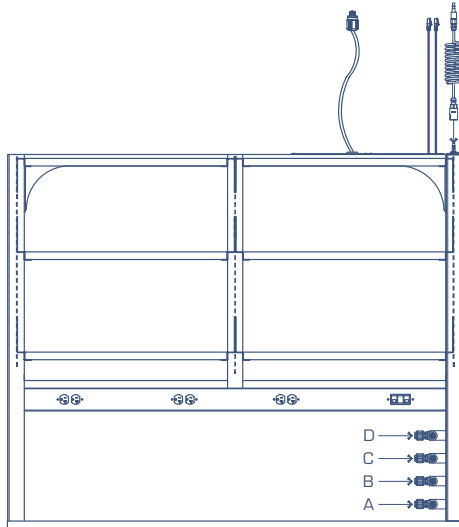

Model no.	Service	Position	Need to be determined	
			On left post	On right post
SYS-GAS	Single Gas	C		
SYS-AIR	Single Air	B		
SYS-VAC	Single Vacuum	A		
SYS-NIT	Single Nitrogen	D		
SYD-GAS	Double Gas	C		
SYD-AIR	Double Air	B		
SYD-VAC	Double Vacuum	A		
SYD-NIT	Double Nitrogen	D		

Each plumbing fixture kit includes a Water Saver needle valve outlet, the stainless steel pre-piping inside the upright fixed to a male quick connect on top of the upright, and a flexible coiled hose (10' length) with quick connect fixtures at both ends).

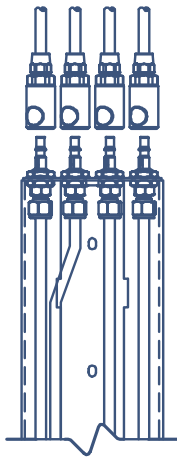

White powder coated finish
Water Saver Fixtures

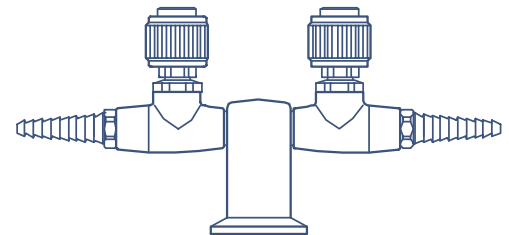

19/32" ID Stainless steel
plumbing lines inside the upright

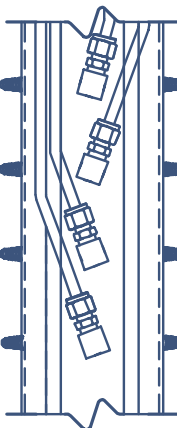

Male quick connect fixture on
top of upright

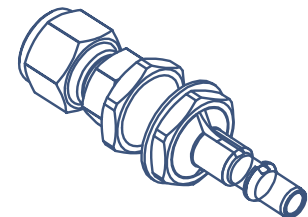

White polyurethane coiled hose
5/16" ID x 15/42" OD

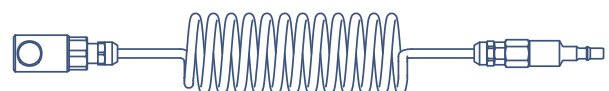

SYMPHONY II SYSTEM

page 20

The Symphony table system is designed to integrate electrical outlets at these three locations:

- ▶ Distribution center raceway (page 12)
 - ▶ On one side for single-sided tables
 - ▶ On both sides for double-sided tables
 - ▶ Maximum of 5 duplex outlets per table side
 - ▶ Maximum of 2 circuits per table side
- ▶ Stand alone electrical outlet upright (page 13)
 - ▶ Maximum of 4 duplex outlets per stand alone upright
 - ▶ Maximum of 2 circuits per stand alone upright
- ▶ Under bench upright
 - ▶ Maximum of 2 duplex outlets per table
 - ▶ The outlet(s) need to be connected to one of raceway circuits

All outlets are factory pre-wired into a different upright from the plumbing and data services and directed through the top channel to the same end as the plumbing and data fixture connections.

Each standard connecting circuit into the Distribution Centers are supplied with a 4 feet cord and twist lock plug over the top channel with a 65 lbs cable retainer clips.

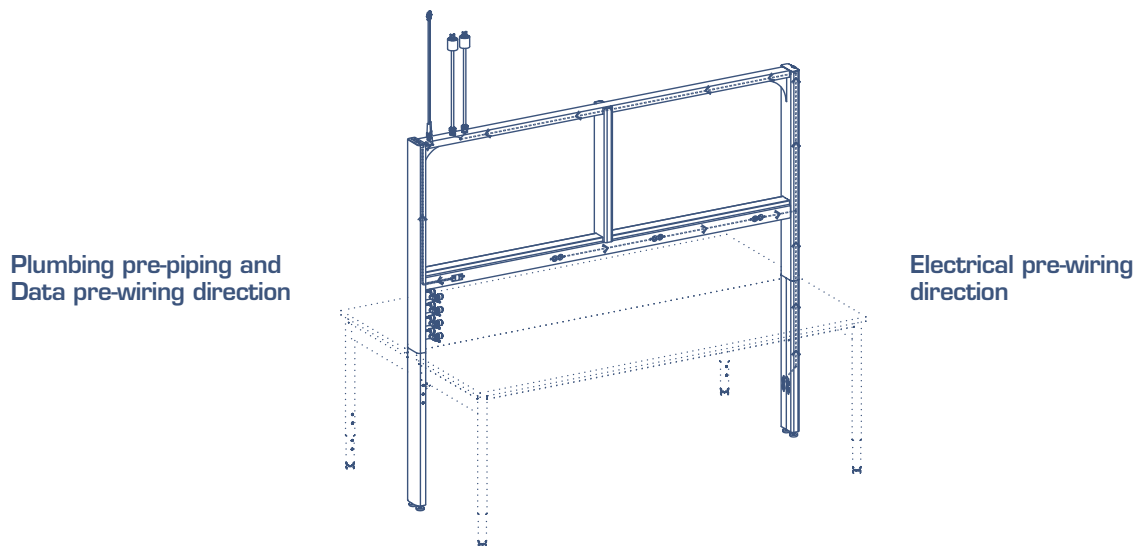

The Symphony table system is designed to integrate data outlets at these three locations:

- ▶ Distribution center raceway (page 12)
 - ▶ On one side for single-sided tables
 - ▶ On both sides for double-sided tables
 - ▶ Maximum of 4 Cat 6 jacks per table side
- ▶ Stand alone electrical/Data outlet upright (page 13)
 - ▶ Maximum of 4 Cat 6 jacks per stand alone upright

All data are factory pre-wired into a different upright from the electrical wiring and directed through the top channel to the same end as the plumbing connections. A four (4) feet long cord with a male jack over the table is supplied for each outlet.

Ceiling Service Panels

Ceiling Service Panels (painted steel) designed to fit the tegular tile style and to be integrated into the suspended ceiling grid.

Half tile panel:

- ▶ Painted steel panel of 11 7/8" x 23 7/8" x 1"
- ▶ Compatible with most "T" grid suspended ceiling structures
- ▶ Panel supplied with UL certified junction boxes and plumbing quick connect fixtures installed at the factory.
- ▶ Designed to fit up to eight (8) plumbing fixtures and six (6) junction boxes for electrical plugs or data fixtures
- ▶ Model no. SYC-P1

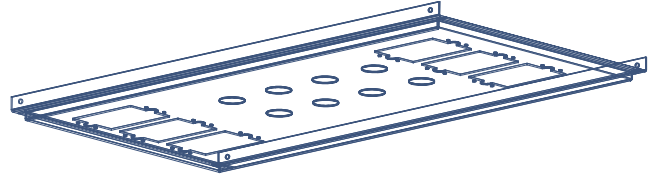

Full tile panel:

- ▶ Painted steel panel of 23 7/8" x 23 7/8" x 1"
- ▶ Compatible with most "T" grid suspended ceiling structures
- ▶ Panel supplied with UL certified junction boxes and plumbing quick connect fixtures installed at the factory.
- ▶ Designed to fit up to eight (8) plumbing fixtures and eight (8) junction boxes for electrical plugs or data fixtures
- ▶ Model no. SYC-P1

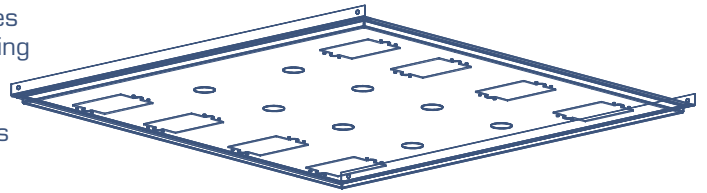

Standard plumbing female quick connect fixtures to be integrated into the panel:

- ▶ Will fit the quick connect hoses supplied with the Symphony II tables
- ▶ Installed at the factory on the Ceiling Service Panel
- ▶ 1/4" Stainless steel body with push button, 3/8" FNPT, dual shut-off valve and keyed per service type
- ▶ UL certified fixtures
 - ▶ For Gas Model no. SYF-G
 - ▶ For Air Model no. SYF-A
 - ▶ For Vacuum Model no. SYF-V
 - ▶ For Nitrogen Model no. SYF-N
 - ▶ For Water Model no. SYF-W

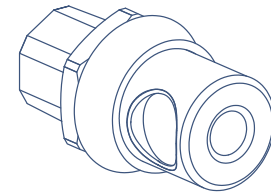

Standard electrical female twist lock plugs to be integrated into the panel:

- ▶ Will fit the plugs supplied with the Symphony II tables
- ▶ To be supplied loose with the panels
- ▶ UL certified fixtures
 - ▶ 1-circuit 120V/20A plug Model no. SY-CF1-120
 - ▶ 2-circuit 120V/20A plug Model no. SY-CF2-120
 - ▶ 3-circuit 120V/20A plug Model no. SY-CF3-120
 - ▶ 1-circuit 208V/30A plug Model no. SY-CF1-208



Standard data female outlets to be integrated into the panel:

- ▶ Will fit the plugs supplied with the Symphony II tables
- ▶ To be supplied loose with the panels
 - ▶ 1 Cat 6 outlet with 1 jack Model no. SY-DF1-C6
 - ▶ 1 Cat 6 outlet with 2 jacks Model no. SY-DF2-C6
 - ▶ 1 Cat 6 outlet with 3 jacks Model no. SY-DF3-C6
 - ▶ 1 Cat 6 outlet with 4 jacks Model no. SY-DF4-C6

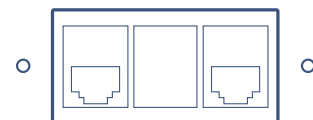

CUSTOMER: _____

PROJECT NAME: _____

MODEL NO.: _____

QUANTITY REQUIRED: _____

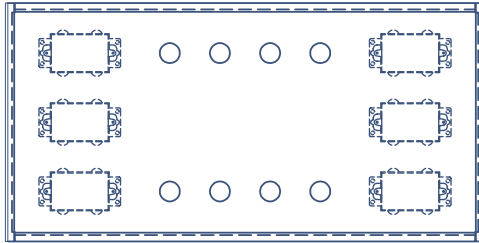

11 7/8" x 23 7/8" panel

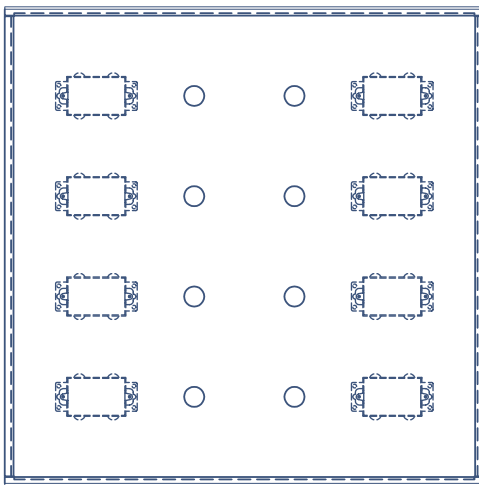

23 7/8" x 23 7/8" panel

1 CEILING ENCLOSURE:

- 11 7/8" x 23 7/8"
- 23 7/8" x 23 7/8"

Each panel supplied with:

Eight (8x) holes for plumbing quick connect fixtures. Non-used holes will be supplied with a black cap.

Six (6x) or eight (8x) cut outs with junction boxes for electrical or data outlets. Non-used cut outs will be supplied with a blank cover over the junction box.

2 FEMALE QUICK CONNECT FIXTURES:

- Gas quick connect fixture
- Air quick connect fixture
- Vacuum quick connect fixture
- Nitrogen quick connect fixture
- Water quick connect fixture
- Other service _____

- Model no. SYF-G Qty: _____
- Model no. SYF-A Qty: _____
- Model no. SYF-V Qty: _____
- Model no. SYF-N Qty: _____
- Model no. SYF-W Qty: _____

3 FEMALE ELECTRICAL AND DATA PLUGS:

- 120V/20A one circuit plug Model no. SY-CF1-120 Qty: _____
- 120V/20A two circuit plug Model no. SY-CF2-120 Qty: _____
- 120V/20A three circuit plug Model no. SY-CF3-120 Qty: _____
- 208V/30A one circuit plug Model no. SY-CF1-208 Qty: _____
- Cat 6 Data outlet with 1 jack Model no. SY-DF1-C6 Qty: _____
- Cat 6 Data outlet with 2 jacks Model no. SY-DF2-C6 Qty: _____
- Cat 6 Data outlet with 3 jacks Model no. SY-DF3-C6 Qty: _____
- Cat 6 Data outlet with 4 jacks Model no. SY-DF4-C6 Qty: _____

Single-sided table order sheet

CUSTOMER: _____

PROJECT NAME: _____

MODEL NO.: _____

QUANTITY REQUIRED: _____

- 1** Full 48" high Distribution Centre: (per page 12) Model no. _____
 Low18" high Distribution Centre (per page 12) Model no. _____
 Single plumbing service upright (per page 13) Model no. _____
 Single Electrical/Data service upright (per page 13) Model no. _____
- 2** Top shelving (1 kit per assembly) (per page 16) Model no. _____
 Top shelf retainer rods or angles (per page 18) Model no. _____
- 3** Middle/Bottom shelving (per page 17) Model no. _____
 Middle/Bottom shelf retainer rods or angles (per page 18) Model no. _____
 Wall cabinet support bracket kit (per page 19) Model no. _____

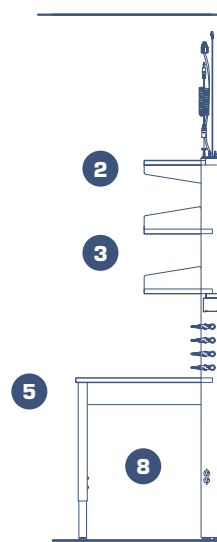
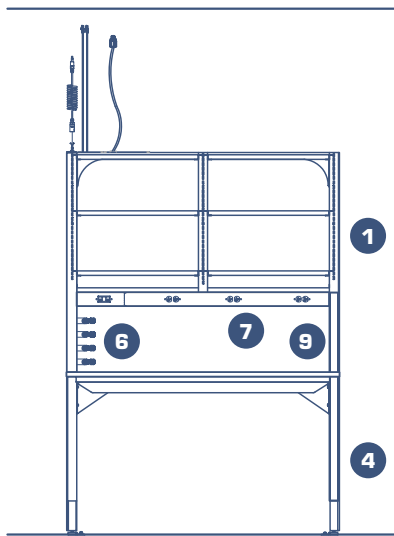

- 4** Work surface table structure (per page 11) Model no. _____
 Free standing distribution stand (per page 13) Model no. _____
 Table seismic brackets (per page 13) Model no. _____
- 5** Counter top (1 top per assembly) (per page 15) Model no. _____
 Painted steel back spacer (per page 15) Model no. _____
- 6** Plumbing fixtures Per page 21): Model no. _____
 Position A Model no. _____
 Position B Model no. _____
 Position C Model no. _____
 Position D Model no. _____
 Post location – Left or Right _____
- 7** Raceway components (per page 21):

120V/20A duplex outlet	Qty on 1 side	_____
120V/20A GFCI duplex outlet	Qty on 1 side	_____
208V/30A single outlet	Qty on 1 side	_____
Cat 5 data outlet	Qty on 1 side	_____
Cat 6 data outlet	Qty on 1 side	_____
- 8** Under bench additional 120V/20A duplex outlet located on the center leg Qty _____
- 9** Linoleum tack board between the top and raceway (per page 19) Model no. _____
 Plexiglas sheet divider (per page 19) Model no. _____

CUSTOMER: _____

PROJECT NAME: _____

MODEL NO.: _____

QUANTITY REQUIRED: _____

- 1** Full 48" high Distribution Centre: (per page 12) Model no. _____
 Low 18" high Distribution Centre (per page 12) Model no. _____
 Single plumbing service upright (per page 13) Model no. _____
 Single Electrical/Data service upright (per page 13) Model no. _____
- 2** Top shelving (2 kits per assembly) (per page 16) Model no. _____
 Top shelf retainer rods or angles (per page 18) Model no. _____
- 3** Middle/Bottom shelving (per page 17) Model no. _____
 Middle/Bottom shelf retainer rods or angles (per page 18) Model no. _____
 Wall cabinet support bracket kit (per page 19) Model no. _____

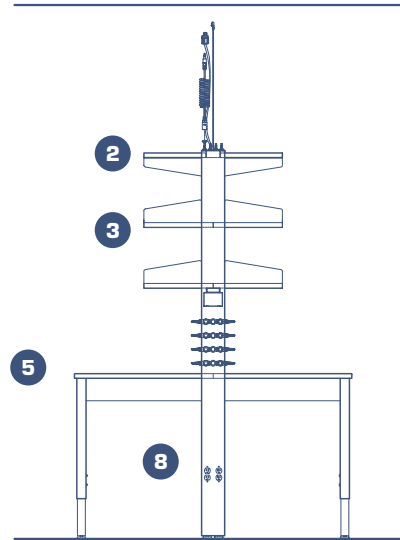
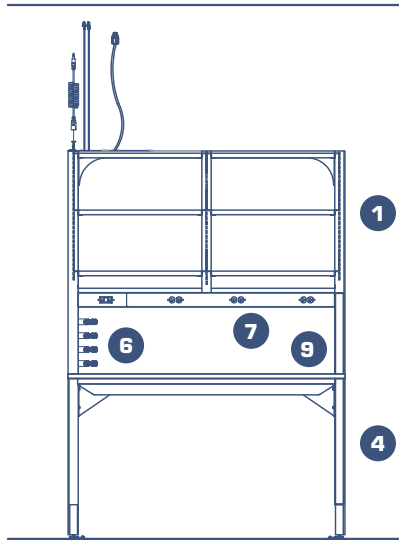

- 4** Work surface table structure (per page 11) Model no. _____
 Free standing distribution stand (per page 13) Model no. _____
 Table seismic brackets (per page 13) Model no. _____
- 5** Counter top (1 top per assembly) (per page 15) Model no. _____
 Painted steel back spacer (per page 15) Model no. _____
- 6** Plumbing fixtures Per page 21):

Position A	Model no. _____
Position B	Model no. _____
Position C	Model no. _____
Position D	Model no. _____
- 7** Raceway components (per page 21):

120V/20A duplex outlet	Qty on 1 side	_____
120V/20A GFCI duplex outlet	Qty on 1 side	_____
208V/30A single outlet	Qty on 1 side	_____
Cat 5 data outlet	Qty on 1 side	_____
Cat 6 data outlet	Qty on 1 side	_____
- 8** Under bench additional 120V/20A duplex outlet located on the center leg Qty _____
- 9** Linoleum tack board between the top and raceway (per page 19) Model no. _____
 Plexiglas sheet divider (per page 19) Model no. _____



BEDCOLAB LTD

**2305, Francis-Hugues Avenue
Laval, Quebec, Canada H7S 1N5**

Phone: 514.384.2820 / 1.800.461.6414

Fax: 514.384.9210

E-mail: information@bedcolab.com

Web Site: www.bedcolab.com



Authorized dealer: