

Features

- 1 Ergonomic fume hood design.
- 2 Visibility optimization of hood interior.
- 3 Sturdy 18 gauge interior and exterior paneling with SEFA-8 superior chemical resistant paint finish.
- 4 Low voltage LED lamp.
- 5 Low profile by-pass opening.
- 6 Ergonomic flush sill with secondary spill trough.
- 7 Possibility to integrate up to eight full-pre-piped plumbing fixtures.
- 8 Safely designed with 1/4" laminated glass on all four sides.

Constant Air Volume (CAV) hoods

Width	Depth	For open-back or double-sided hoods with rear glass panel	For hoods against a wall with rear painted steel panel
48"	32.75"	VIS-48A-G	VIS-48A-S
60"	32.75"	VIS-60A-G	VIS-60A-S
72"	32.75"	VIS-72A-G	VIS-72A-S

Variable Air Volume (VAV) hoods

Width	Depth	For open-back or double-sided hoods with rear glass panel	For hoods against a wall with rear painted steel panel
48"	32.75"	VIS-48B-G	VIS-48B-S
60"	32.75"	VIS-60B-G	VIS-60B-S
72"	32.75"	VIS-72B-G	VIS-72B-S

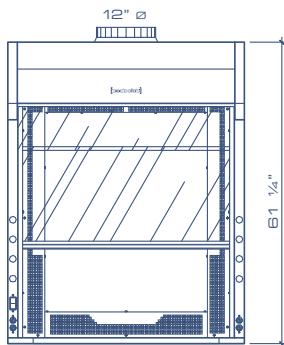
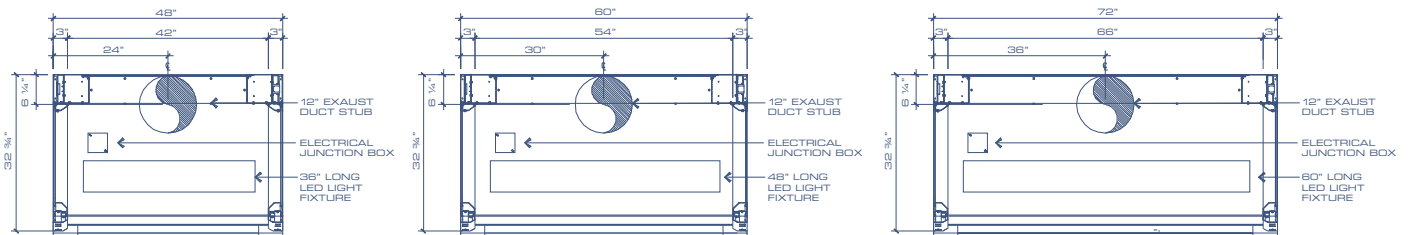

48" hood

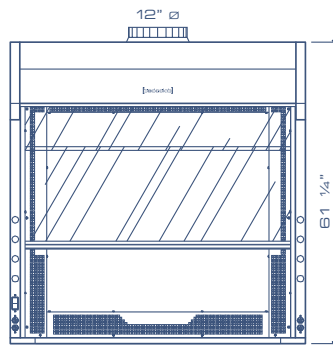

60" hood

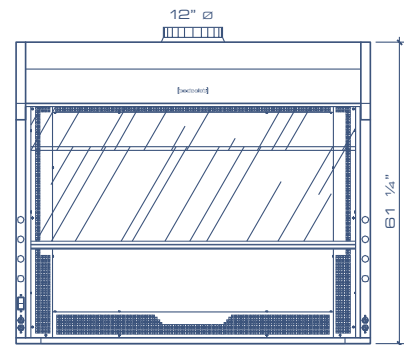

72" hood

Hood dimensions

Fume hood Dimensions	Exterior Dimensions			Maximum Sash Opening	Operation Sash Opening	Interior Dimensions			Viewing Dimensions	
	Width	Depth	Height			Width	Depth	Height	Front View	Back view
48" type	48"	32.75"	61.25"	42" x 27.25"	42" x 18"	42"	24.5"	48"	42" x 47"	33" x 40.5"
60" type	60"	32.75"	61.25"	54" x 27.25"	54" x 18"	54"	24.5"	48"	54" x 47"	45" x 40.5"
72" type	72"	32.75"	61.25"	66" x 27.25"	66" x 18"	66"	24.5"	48"	66" x 47"	57" x 40.5"

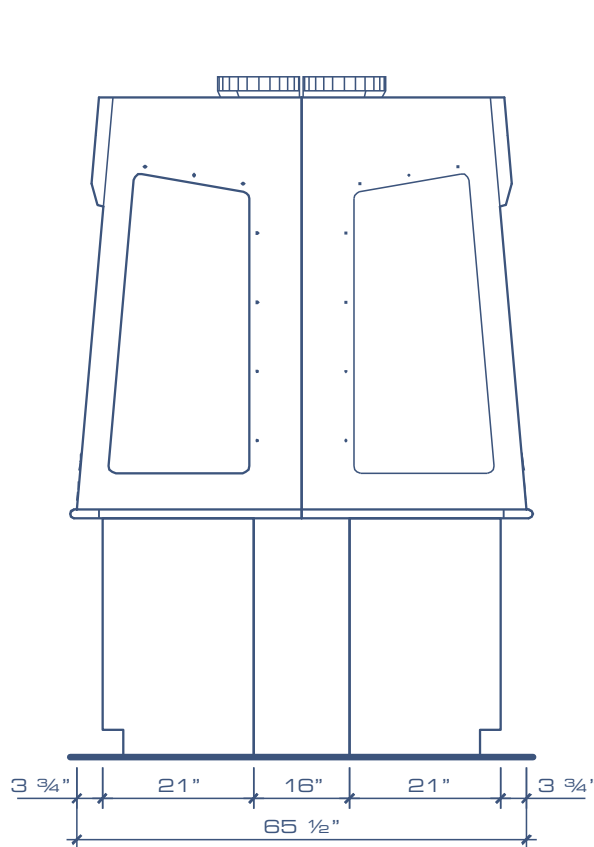

**Double-sided hoods
(2 hoods back-to-back)**

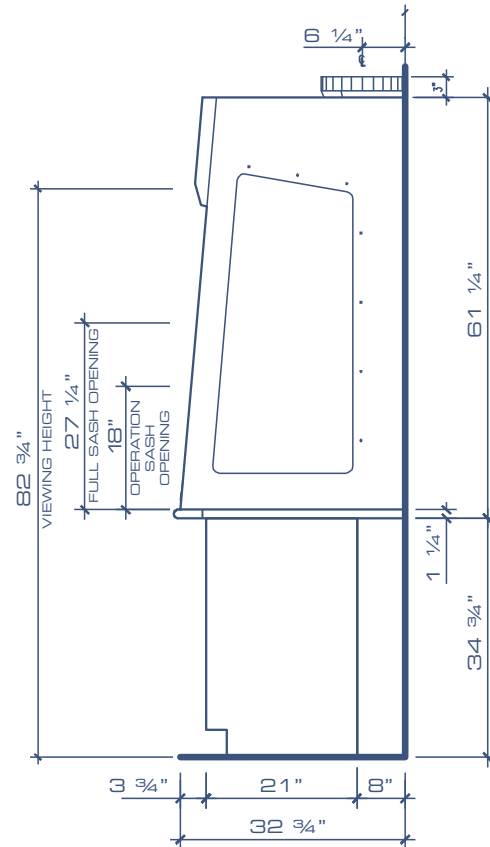

**Single hoods (with rear glass panel
or rear painted steel panel)**

Hood exhaust data

Exhaust data with 18" open sash												
				100 feet/minute velocity			80 feet/minute velocity			60 feet/minute velocity		
Hood width	Face Opening	Duct collar size	Duct collar adapter	Exhaust CFM	12" Duct collar FPM	Static pressure lost	Exhaust CFM	12" Duct collar FPM	Static pressure lost	Exhaust CFM	12" Duct collar FPM	Static pressure lost
48"	42" x 18"	4" x 20"	12" Ø	525	669	0.25"	420	535	0.25"	315	401	0.20"
60"	54" x 18"	4" x 20"	12" Ø	675	860	0.28"	540	688	0.28"	405	516	0.23"
72"	66" x 18"	4" x 20"	12" Ø	825	1050	0.30"	660	840	0.30"	495	630	0.25"

It is recommended to add a 3 % safety leak factor to all above exhaust calculated volumes in order to compensate normal site system air leakage.

Fume hood counter tops 1 1/4" thick with raised edges

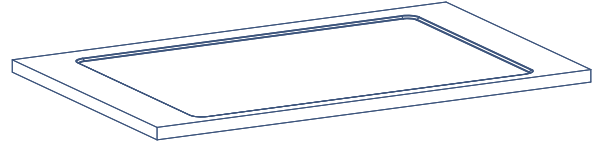

Hood width	Surface sizes	Product numbers			
		Black epoxy resin	Stainless steel T.304 on channel structure	Stainless steel T.316 on particle board	Stainless steel T.316 on channel structure
48"	48" x 29 1/2"	VI-EP-4829	VI-SS-4829	VI-SP-4829	VI-SC-4829
60"	60" x 29 1/2"	VI-EP-6029	VI-SS-6029	VI-SP-6029	VI-SC-6029
72"	72" x 29 1/2"	VI-EP-7229	VI-SS-7229	VI-SP-7229	VI-SC-7229

Sinks and Cup sinks



Model no.	Sizes (W x D x H)	Description
VCS-4R	6" x 3" x 4"	Black polypropylene oval cup sink
VCS-04	5.7" x 2.7" x 3.7"	Black epoxy resin oval cup sink
VCS-07	6.3" Ø x 6"	Black epoxy resin round cup sink
VCS-18	13.6" x 4.4" x 5.8"	Black epoxy resin rectangular cup sink
VCS-4A	6" x 3" x 4"	Stainless steel cup sink

Standard electrical components and hood Alarm

All hoods are supplied with the following electrical components as standard features:

- ▶ Two (2) 120V/20A electrical duplex outlets per hood (1 per side post),
- ▶ A LED lamp located over a sealed safety glass and connected to a light switch located on the left front post
- ▶ Pre-wiring of all components to a junction box located on top of the hood.

OPTIONAL DIGITAL FUME HOOD MONITOR

Model no. **ROOSTER Sensor 100**

- ▶ Air Velocity and temperature sensor with touch screen display using an instrumentation grade sensing element installed into the top hood collar.

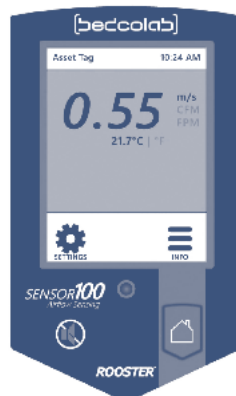

OPTIONAL FACTORY MADE CUT OUT FOR VAV CONTROL PANEL

- ▶ Cut out would be made upon VAV control brand model and type cut sheets supplied by the client.

Fume hood ceiling enclosure options – need indication of enclosure type, hood size and configuration on page 7 Fume Hood Specification sheet.

ADJUSTABLE CEILING ENCLOSURE ASSEMBLY

- ▶ Full height adjustable panel assembly that covers full space between fume hood and finished ceiling – Removable front panel tight in with screws

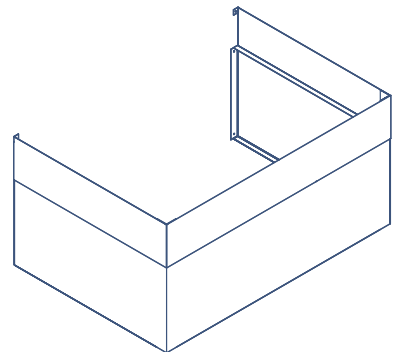

Hood width	Panels on	Panel height	Ceiling height	Model no.
48"	Front + 2 sides	12"	108"	VCE-4812
60"	Front + 2 sides	12"	108"	VCE-6012
72"	Front + 2 sides	12"	108"	VCE-7212
48"	Front, back + 2 sides	12"	108"	VCF-4812
60"	Front, back + 2 sides	12"	108"	VCF-6012
72"	Front, back + 2 sides	12"	108"	VCF-7212

SELF SUPPORTED CEILING ENCLOSURE ASSEMBLY

- ▶ 11" high fixed height panel assembly that covers the space between fume hood top and 1" below the 108" finished ceiling. Side panels are fixed to the fume hood with a front/back panels easily removable (no apparent screws)

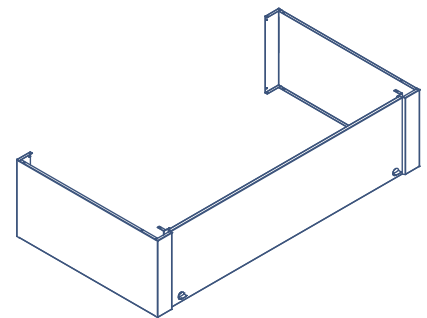

Hood width	Panels on	Panel height	Ceiling	Model no.
48"	Front + 2 sides	11"	108"	VCG-4811
60"	Front + 2 sides	11"	108"	VCG-6011
72"	Front + 2 sides	11"	108"	VCG-7211
48"	Front, back + 2 sides	11"	108"	VCH-4811
60"	Front, back + 2 sides	11"	108"	VCH-6011
72"	Front, back + 2 sides	11"	108"	VCH-7211

Distillation rack options – installed into the plenum space leaving full counter space depth free of use

ALUMINUM DISTILLATION RACK ASSEMBLIES

Hood width	Rack sizes (W x H)	Model no.	Quantity of vertical rods	Quantity of horizontal rods
48"	33" x 40.5"	VIA-48	2	2
60"	45" x 40.5"	VIA-60	2	2
72"	57" x 40.5"	VIA-72	3	2

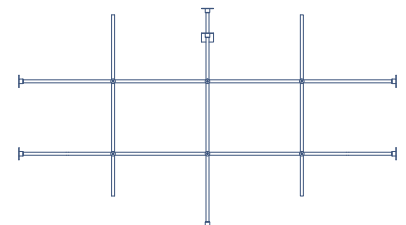

STAINLESS STEEL DISTILLATION RACK ASSEMBLIES

Hood width	Rack sizes (W x H)	Model no.	Quantity of vertical rods	Quantity of horizontal rods
48"	33" x 40.5"	VIS-48	2	2
60"	45" x 40.5"	VIS-60	2	2
72"	57" x 40.5"	VIS-72	3	2

Plumbing - Fixtures

All Vision plumbing fixtures to be supplied with front loaded remote controlled valves pre-piped with 3/8" copper tubing up to 6" over the top of the hood.

For Air, Vacuum or Nitrogen outlets: Front loaded remote controlled needle valve with 45 ° angle panel mounted outlet fitting.

Service	Model no.	Finish Color
Air	CT740N-LR-AIR	Orange
Vacuum	CT740N-LR-VAC	Yellow
Nitrogen	CT740N-LR-NIT	Brown



For burning gas outlets: Front loaded remote controlled needle valve with pop-up indicator buttons and with 45 ° angle panel mounted outlet fitting.

Service	Model no.	Finish Color
Burning gas	CT740-GI-GAS	Blue



For cold water faucets: Front loaded remote controlled needle valve with rigid/swing vacuum breaker goose-neck panel mounted outlet.

Service	Model no.	Finish Color
Water	CT074WSA-9RSVB	Green



For ADA requirements using the same above plumbing fixtures but supplied with lever handles:

Service	Model no.	Finish Color
Air	CT740N-LR-AIR-CTBA220	Orange
Vacuum	CT740N-LR-VAC-CTBA220	Yellow
Nitrogen	CT740N-LR-NIT-CTBA220	Brown
Burning gas	CT740-GI-GAS-CTBA220	Blue
Water	CT074WSA-9RSVB-CTBA220	Green

CUSTOMER: _____ PROJECT NAME: _____

MODEL NO.: _____ QUANTITY REQUIRED: _____

- 1 CEILING ENCLOSURE:**
- | | | |
|------------------------------|--------------------------------|--------------------------------|
| <input type="checkbox"/> VCE | <input type="checkbox"/> Front | <input type="checkbox"/> Back |
| <input type="checkbox"/> VCG | <input type="checkbox"/> Left | <input type="checkbox"/> Right |

CEILING HEIGHT: _____

2 SEISMIC BRACE
MODEL NO. _____

3 REQUIRED SERVICES:

Standard light switch
 Standard 120V/20A outlet

Cup Sink _____

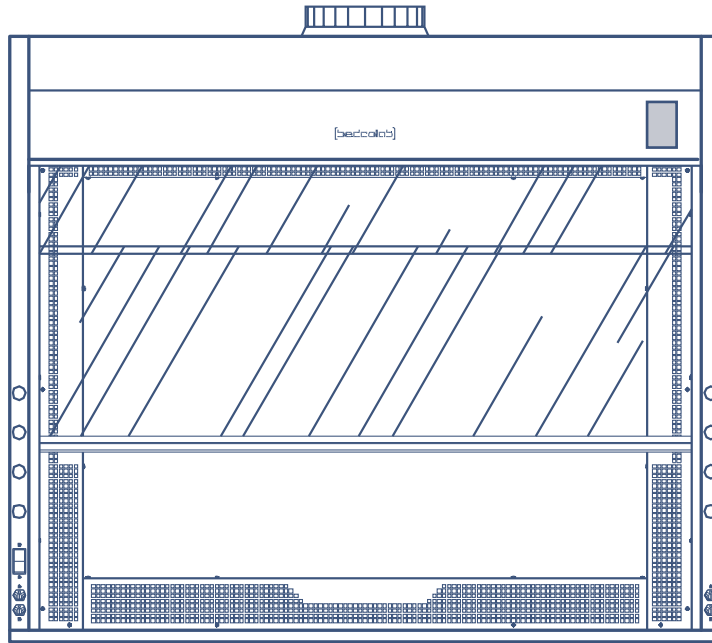

3 REQUIRED SERVICES:

- Alarm required
 VAV control

Standard 120V/20A outlet

 Cup Sink

4 PLUMBING PRE-PIPING: Standard for all services using flexible 3/8" copper up to 6" over the top of the hood

7 SASH STOP: Standard gravity sash stop model no. VSS-01

8 DISTILLATION RACK:

- Aluminum rack - Model no. _____
 Stainless steel rack - Model no. _____



BEDCOLAB LTD

**2305, Francis-Hugues Avenue
Laval, Quebec, Canada H7S 1N5**

Phone: 514.384.2820 / 1.800.461.6414

Fax: 514.384.9210

E-mail: information@bedcolab.com

Web Site: www.bedcolab.com



Authorized dealer: